



## Features and Benefits

- Operating Input Voltage Range: 2.3 V to 6.5 V
- Maximum Output Current:
  - TGS7172 Output Current: 2 A
  - TGS7171 Output Current: 1 A
  - TGS7170 Output Current: 0.5 A
- Low noise: 5  $\mu$ V rms independent of output voltage at 100 Hz to 100 kHz
- Fast transient response: 1.5  $\mu$ s for 1 mA to 1.5 A load step
- High Power Supply Ripple Rejection: 60 dB PSRR at 100 kHz
- Low dropout voltage:
  - TGS7172: 135 mV at 2 A load,  $V_{OUT} = 3$  V
  - TGS7171: 70 mV at 1 A load,  $V_{OUT} = 3$  V
  - TGS7170: 35 mV at 0.5 A load,  $V_{OUT} = 3$  V
- Initial accuracy:  $-0.8\%$  (minimum),  $+0.7\%$  (maximum)
- Accuracy over line, load, and temperature:  $\pm 1.5\%$
- Quiescent current,  $I_{GND} = 0.7$  mA with no load
- Low shutdown current: 0.25  $\mu$ A at  $V_{IN} = 5$  V
- Stable with small 4.7  $\mu$ F ceramic output capacitor
- Adjustable and fixed output voltage options: 1.2 V to 5.0 V
- Adjustable output from 1.2 V to  $V_{IN} - V_{DO}$
- Precision enable and Adjustable soft start
- 8-lead, 3 mm  $\times$  3 mm LFCSP package

## General Description

The TGS717X is a CMOS low dropout regulator that operates from 2.3 V to 6.5 V and provides up to 2A / 1 A / 0.5 A of output current. This high output current LDO is ideal for regulation of high performance analog and mixed-signal circuits operating from 6 V down to 1.2 V rails. Using an advanced proprietary architecture, the device provides high power supply rejection and low noise and achieves excellent line and load transient response with just a small 4.7  $\mu$ F ceramic output capacitor. Load transient response is typically 1.5  $\mu$ s for a 1 mA to 1.5 A load step.

The TGS717X is available in 17 fixed output voltage options. The following voltages are available from

stock: 1.3 V, 1.8 V, 2.5 V, 3.0 V, 3.3 V, 4.2 V, and 5.0 V. Additional voltages that are available by special order are: 1.5 V, 1.85 V, 2.0 V, 2.2 V, 2.7 V, 2.75 V, 2.8 V, 2.85 V, 3.8 V, and 4.6 V. An adjustable version is also available that allows output voltages that range from 1.2 V to  $V_{IN} - V_{DO}$  with an external feedback divider.

Inrush current can be controlled by adjusting the start-up time via the soft start pin. The typical start-up time with a 1 nF soft start capacitor is 1.0 ms.

### Applications

- Regulation to noise sensitive applications:  
ADC and DAC circuits, precision amplifiers, PLLs/VCOs, and clocking ICs
- Communications and infrastructure
- Medical and healthcare
- Industrial and instrumentation

### Functional Block Diagram and Pin Description

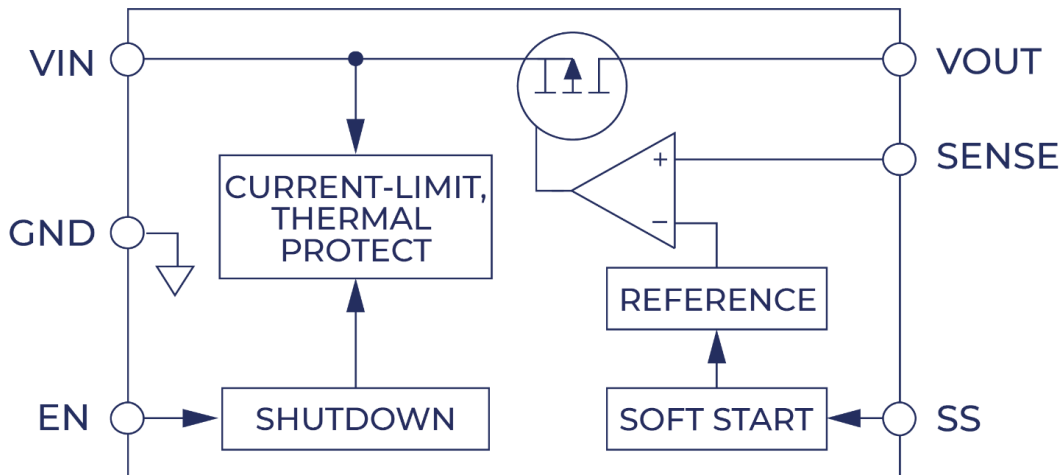
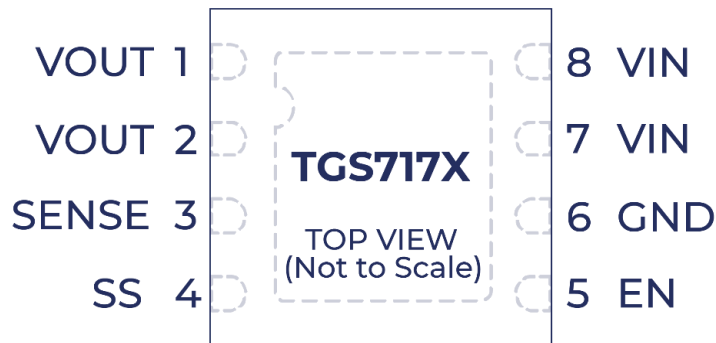

Figure 1. Functional Block Diagram

### Pin Configurations (Top View)



## Pin Description

| Pin   |     | Description  |
|-------|-----|--|
| Type  | No. |  |
| VOUT  | 1   | Regulated Output Voltage. Bypass this pin to GND with a 4.7 $\mu$ F or greater capacitor.  |
| VOUT  | 2   | Regulated Output Voltage. This pin is internally connected to Pin 1.   |
| SENSE | 3   | Sense Input. Connect this pin as close as possible to the load for best load regulation. Use an external resistor divider to set the output voltage higher than the fixed output voltage.  |
| SS    | 4   | Soft Start. A 1 nF external capacitor connected to SS results in a 1.0 ms start-up time.   |
| EN    | 5   | Regulator Enable. Drive EN high to turn on the regulator; drive EN low to turn off the regulator. For automatic startup, connect EN to VIN (Pin 7 or Pin 8).   |
| GND   | 6   | Ground   |
| VIN   | 7   | Regulator Input Supply. Bypass this pin to GND with a 4.7 $\mu$ F or greater capacitor.  |
| VIN   | 8   | Regulator Input Supply. This pin is internally connected to Pin 7.   |
| EP    |     | Exposed Pad. The exposed pad is on the bottom of the package. The exposed pad enhances thermal performance and is electrically connected to GND inside the package. Connect the exposed pad to the ground plane on the board to ensure proper operation. |

Limiting Value – In accordance with the Absolute Maximum Rating System (IEC 60134).

| Parameter                              | Min. | Max.            | Unit |
|--|------|-----------------|------|
| Input Voltage                          | -0.3 | 7               | V    |
| Output Voltage                         | -0.3 | V <sub>IN</sub> | V    |
| Enable Voltage                         | -0.3 | 7               | V    |
| Soft-start Voltage                     | -0.3 | V <sub>IN</sub> | V    |
| Sense Voltage                          | -0.3 | 7               | V    |
| Maximum Operating Junction Temperature | -65  | 150             | °C   |
| Operating Temperature Range            | -40  | 125             | °C   |
| Storage Temperature Range              | -65  | 150             | °C   |
| Lead Temperature (Soldering, 10 sec)   |      | 260             | °C   |
| Thermal Resistance, Junction-to-Air    |      | 36.4            | °C/W |
| ESD (Human Body Model)                 |      | 7               | kV   |
| ESD (Capability)                       |      | 2               | kV   |

(1) Stresses beyond those listed under “Absolute Maximum Ratings” may cause permanent damage to the device. These are stress ratings only, and functional operation of the device at these or any other conditions beyond those indicated in the operational sections of the specifications is not implied. Exposure to absolute maximum rating conditions for extended periods may affect device reliability.

## Ordering Information

| Type Number     | Output Voltage | Package Name | Package Quantity | Operating Temperature | Marking Code |
|-----------------|----------------|--------------|------------------|-----------------------|--------------|
| TGS7172S13ILCPR | 1.3 V          | LFCSP-8      | 5000             | -40°C to +125°C       | SPE13        |
| TGS7172S18ILCPR | 1.8 V          | LFCSP-8      | 5000             | -40°C to +125°C       | SPE18        |
| TGS7172S25ILCPR | 2.5 V          | LFCSP-8      | 5000             | -40°C to +125°C       | SPE25        |
| TGS7172S30ILCPR | 3.0 V          | LFCSP-8      | 5000             | -40°C to +125°C       | SPE30        |
| TGS7172S33ILCPR | 3.3 V          | LFCSP-8      | 5000             | -40°C to +125°C       | SPE33        |
| TGS7172S42ILCPR | 4.2 V          | LFCSP-8      | 5000             | -40°C to +125°C       | SPE42        |
| TGS7172S50ILCPR | 5.0 V          | LFCSP-8      | 5000             | -40°C to +125°C       | SPE50        |
| TGS7172SAAILCPR | ADJ            | LFCSP-8      | 5000             | -40°C to +125°C       | SPEAA        |
| TGS7171S13ILCPR | 1.3 V          | LFCSP-8      | 5000             | -40°C to +125°C       | SP113        |
| TGS7171S18ILCPR | 1.8 V          | LFCSP-8      | 5000             | -40°C to +125°C       | SP118        |
| TGS7171S25ILCPR | 2.5 V          | LFCSP-8      | 5000             | -40°C to +125°C       | SP125        |
| TGS7171S30ILCPR | 3.0 V          | LFCSP-8      | 5000             | -40°C to +125°C       | SP130        |
| TGS7171S33ILCPR | 3.3 V          | LFCSP-8      | 5000             | -40°C to +125°C       | SP133        |
| TGS7171S42ILCPR | 4.2 V          | LFCSP-8      | 5000             | -40°C to +125°C       | SP142        |
| TGS7171S50ILCPR | 5.0 V          | LFCSP-8      | 5000             | -40°C to +125°C       | SP150        |
| TGS7171SAAILCPR | ADJ            | LFCSP-8      | 5000             | -40°C to +125°C       | SP1AA        |
| TGS7170S13ILCPR | 1.3 V          | LFCSP-8      | 5000             | -40°C to +125°C       | SP013        |
| TGS7170S18ILCPR | 1.8 V          | LFCSP-8      | 5000             | -40°C to +125°C       | SP018        |
| TGS7170S25ILCPR | 2.5 V          | LFCSP-8      | 5000             | -40°C to +125°C       | SP025        |
| TGS7170S30ILCPR | 3.0 V          | LFCSP-8      | 5000             | -40°C to +125°C       | SP030        |
| TGS7170S33ILCPR | 3.3 V          | LFCSP-8      | 5000             | -40°C to +125°C       | SP033        |
| TGS7170S42ILCPR | 4.2 V          | LFCSP-8      | 5000             | -40°C to +125°C       | SP042        |
| TGS7170S50ILCPR | 5.0 V          | LFCSP-8      | 5000             | -40°C to +125°C       | SP050        |
| TGS7170SAAILCPR | ADJ            | LFCSP-8      | 5000             | -40°C to +125°C       | SP0AA        |

## Electrical Characteristics

$V_{IN} = V_{OUT-NOM} + 0.5 \text{ V}$  or  $2.3 \text{ V}$ ,  $EN = V_{IN}$ ,  $I_{OUT} = 10 \text{ mA}$ ,  $T_A = 25^\circ\text{C}$ ,  $C_{IN} = C_{OUT} = 4.7 \mu\text{F}$ , unless otherwise noted

| Parameter                          | Symbol                    | Test Conditions  | Min.  | Type | Max.  | Unit                   |
|------------------------------------|---------------------------|--|-------|------|-------|------------------------|
| Input Voltage Operation Range      | $V_{IN}$                  |  | 2.3   |      | 6.5   | V                      |
| Fixed Output Voltage Accuracy      | $V_{OUT}$                 | $I_{LOAD} = 10 \text{ mA}$ , $T_J = 25^\circ\text{C}$  | -0.8  | 0.7  |       | %                      |
|                                    |                           | $I_{LOAD} = 100 \mu\text{A}$ to $2 \text{ A}$ ,<br>$V_{IN} = (V_{OUT} + 0.5 \text{ V})$ to $6.5 \text{ V}$ | -1.5  |      | 1.5   |                        |
| Adjustable Output Voltage Accuracy | $V_{SENSE}$               | $I_{LOAD} = 10 \text{ mA}$   | 1.194 | 1.2  | 1.212 | %                      |
|                                    |                           | $I_{LOAD} = 100 \mu\text{A}$ to $2 \text{ A}$ ,<br>$V_{IN} = (V_{OUT} + 0.5 \text{ V})$ to $6.5 \text{ V}$ | 1.182 |      | 1.218 |                        |
| Line Regulation                    | $\Delta V_{O(\Delta VI)}$ | $V_{IN} = V_{OUT-NOM} + 0.5 \text{ V}$ to $6.5 \text{ V}$  | -0.1  |      | 0.1   | %/V                    |
| Load Regulation                    | $\Delta V_{O(\Delta IO)}$ | $I_{OUT} = 100 \mu\text{A}$ to $2 \text{ A}$   |       | 0.1  | 0.3   | %/A                    |
| Load Current                       | $I_{LOAD}$                | TGS7172  |       |      | 2     | A                      |
|                                    |                           | TGS7171  |       |      | 1     |                        |
|                                    |                           | TGS7170  |       |      | 0.5   |                        |
| Ground Current                     | $I_{GND}$                 | $I_{OUT} = 0 \mu\text{A}$  |       | 0.7  | 2     | mA                     |
|                                    |                           | $I_{OUT} = 2 \text{ A}$  |       | 3.5  | 5     |                        |
| Shutdown Current                   | $I_{SHDN}$                | $V_{EN} = 0 \text{ V}$ , $I_{OUT} = 0 \text{ mA}$ , $V_{IN} = 5 \text{ V}$                                 |       | 5    | 10    | $\mu\text{A}$          |
| Output Current Limit               | $I_{OLIM}$                |  | 2.4   | 3.2  | 3.9   | A                      |
| Soft Start Current                 | $I_{SS}$                  | $V_{IN} = 5 \text{ V}$   | 0.5   | 1    | 1.5   | $\mu\text{A}$          |
| Dropout Voltage                    | $V_{DO}$                  | $I_{OUT} = 500 \text{ mA}$ , $V_{OUT} = 3 \text{ V}$   |       | 35   | 70    | mV                     |
|                                    |                           | $I_{OUT} = 1 \text{ A}$ , $V_{OUT} = 3 \text{ V}$  |       | 70   | 135   |                        |
|                                    |                           | $I_{OUT} = 2 \text{ A}$ , $V_{OUT} = 3 \text{ V}$  |       | 135  | 270   |                        |
| Power Supply Rejection Ratio       | PSRR                      | 100 kHz, $V_{IN} = 4.0 \text{ V}$ , $V_{OUT} = 3 \text{ V}$ ,<br>$I_{LOAD} = 1.5 \text{ A}$                |       | 60   |       | $\mu\text{V}_{RMS}$    |
|                                    |                           | 100 kHz, $V_{IN} = 3.5 \text{ V}$ , $V_{OUT} = 3 \text{ V}$ ,<br>$I_{LOAD} = 1.5 \text{ A}$                |       | 53   |       |                        |
|                                    |                           | 100 kHz, $V_{IN} = 3.3 \text{ V}$ , $V_{OUT} = 3 \text{ V}$ ,<br>$I_{LOAD} = 1.5 \text{ A}$                |       | 42   |       |                        |
|                                    |                           | 1 MHz, $V_{IN} = 4.0 \text{ V}$ , $V_{OUT} = 3 \text{ V}$ ,<br>$I_{LOAD} = 1.5 \text{ A}$                  |       | 31   |       |                        |
|                                    |                           | 1 MHz, $V_{IN} = 3.5 \text{ V}$ , $V_{OUT} = 3 \text{ V}$ ,<br>$I_{LOAD} = 1.5 \text{ A}$                  |       | 30   |       |                        |
|                                    |                           | 1 MHz, $V_{IN} = 3.3 \text{ V}$ , $V_{OUT} = 3 \text{ V}$ ,<br>$I_{LOAD} = 1.5 \text{ A}$                  |       | 20   |       |                        |
| Output Voltage Noise               | $V_N$                     | 10 Hz to 100 kHz, all fixed output voltages  |       | 6    |       | nV/ $\sqrt{\text{Hz}}$ |
|                                    |                           | 100 Hz to 100 kHz, all fixed output voltages   |       | 5    |       |                        |
|                                    |                           | 100 Hz, all fixed output voltages  |       | 110  |       |                        |
|                                    |                           | 1 kHz, all fixed output voltages   |       | 40   |       |                        |
|                                    |                           | 10 kHz, all fixed output voltages  |       | 20   |       |                        |
|                                    |                           | 100 kHz, all fixed output voltages   |       | 12   |       |                        |

## Electrical Characteristics

$V_{IN} = V_{OUT-NOM} + 0.5 \text{ V}$  or  $2.3 \text{ V}$ ,  $EN = V_{IN}$ ,  $I_{OUT} = 10 \text{ mA}$ ,  $T_A = 25^\circ\text{C}$ ,  $C_{IN} = C_{OUT} = 4.7 \mu\text{F}$ , unless otherwise noted

| Parameter  | Symbol         | Test Conditions   | Min. | Type | Max. | Unit             |
|--|----------------|---|------|------|------|------------------|
| Start-up time  | $t_{START}$    | $V_{OUT} = 5 \text{ V}$ , $C_{SS} = 0 \text{ nF}$   |      | 380  |      | $\mu\text{s}$    |
|  |                | $V_{OUT} = 5 \text{ V}$ , $C_{SS} = 1 \text{ nF}$   |      | 1    |      | ms               |
| Input Voltage Rising                                       | $UVLO_{RISE}$  | $V_{IN} = 2.3 \text{ V}$ to $6.5 \text{ V}$   |      |      | 2.28 | V                |
| Input Voltage Falling                                      | $UVLO_{FALL}$  |   | 1.94 |      |      | V                |
| Internal UVLO Hysteresis Time for output voltage to settle | $UVLO_{HYS}$   |   |      | 200  |      | mV               |
| Transient Load Response                                    | $t_{TR\_REC}$  | Time for output voltage to settle within $\pm V_{SETTLE}$ from $V_{DEV}$ for a 1 mA to 1.5 A load step, load step rise time = 400 ns            | 1.5  |      |      | $\mu\text{s}$    |
|  | $V_{DEV}$      | Output voltage deviation due to 1 mA to 1.5 A load step   | 35   |      |      | mV               |
|  | $V_{SETTLE}$   | Output voltage deviation after transient load response time ( $t_{TR\_REC}$ has passed, $V_{OUT} = 5 \text{ V}$ , $C_{OUT} = 4.7 \mu\text{F}$ ) | 0.1  |      |      | %                |
| EN Input Logic High  | $V_{EN-HIGH}$  | $V_{IN} = 2.3 \text{ V}$ to $6.5 \text{ V}$   | 1.27 |      |      | V                |
| EN Input Logic Low   | $V_{EN-LOW}$   |   |      |      | 0.4  | V                |
| EN Input Logic Hysteresis                                  | $V_{EN-HY}$    |   |      | 90   |      | mV               |
| EN Input Logic High  | $V_{EN-HIGH}$  | $V_{IN} = 2.3 \text{ V}$ to $6.5 \text{ V}$ , $EN = V_{IN}$ or GND, From EN rising from 0 V to $V_{IN}$ to $0.1 \text{ V} \times V_{OUT}$       | 1.11 | 1.20 | 1.27 | V                |
| EN Input Logic Low   | $V_{EN-LOW}$   |   | 1.01 | 1.10 | 1.16 | V                |
| EN Input Logic Hysteresis                                  | $V_{EN-HY}$    |   |      | 100  |      | mV               |
| EN Input Leakage Current                                   | $I_{EN-LK}$    |   |      | 0.1  |      |                  |
| EN Input Delay Time  | $T_{EN-DLY}$   |   |      |      | 100  |                  |
| VOUT Pull-down Resistance                                  | $V_{OUT-PULL}$ | $EN = 0 \text{ V}$ , $V_{OUT} = 1 \text{ V}$  |      | 4    |      | $\text{K}\Omega$ |
| Thermal Shutdown Temperature                               | $T_{SD}$       | Temperature rising from $T_J = +25^\circ\text{C}$   |      | 150  |      | $^\circ\text{C}$ |
| Thermal Shutdown Hysteresis                                | $T_{SDH}$      | Temperature falling from $T_{SD}$   |      | 15   |      | $^\circ\text{C}$ |

## Typical Performance Characteristics

Note: Typical Characteristics are intended to be used as reference data; they are not guaranteed.

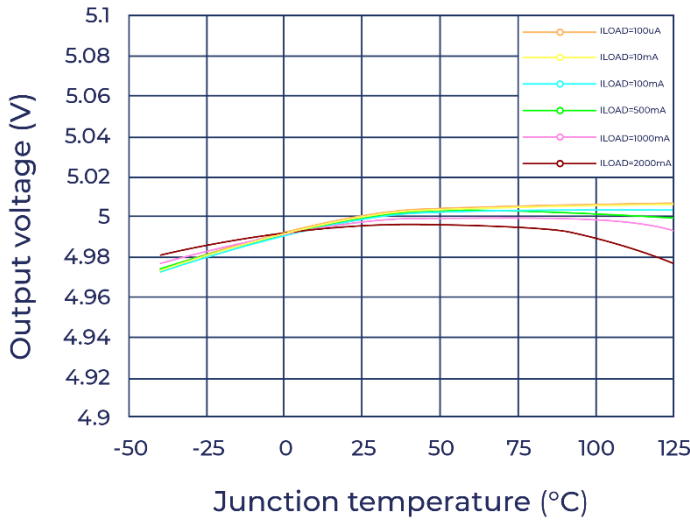

Figure 1. Output voltage vs Junction Temperature

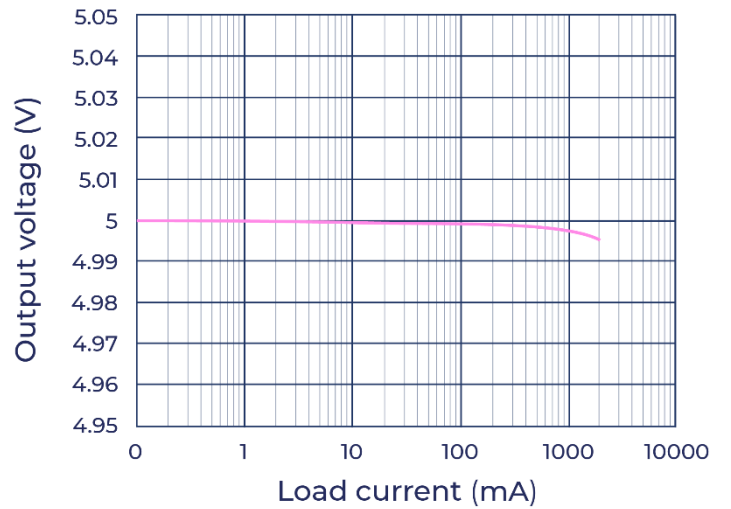

Figure 2. Output voltage vs Load current

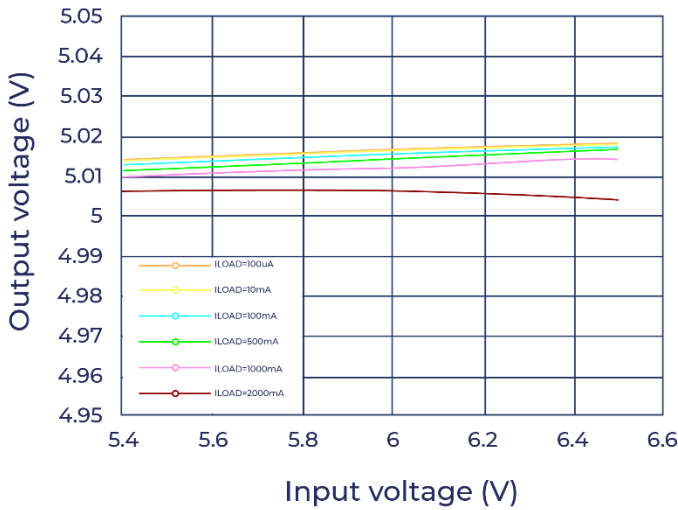

Figure 3. Output voltage vs Input voltage

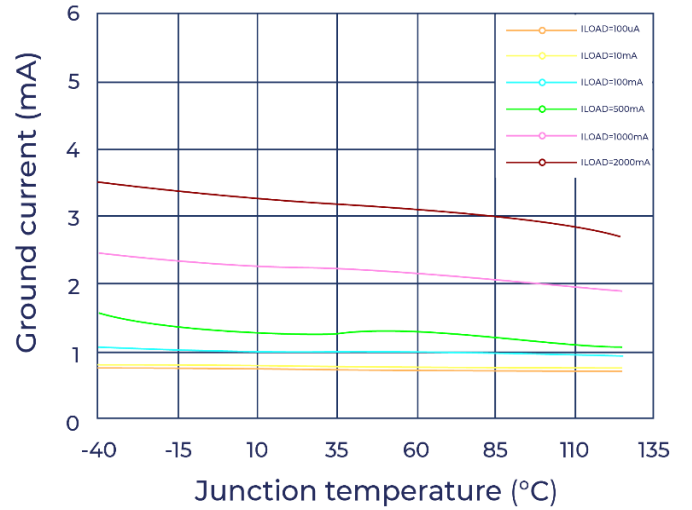

Figure 4. Ground current vs Junction temperature

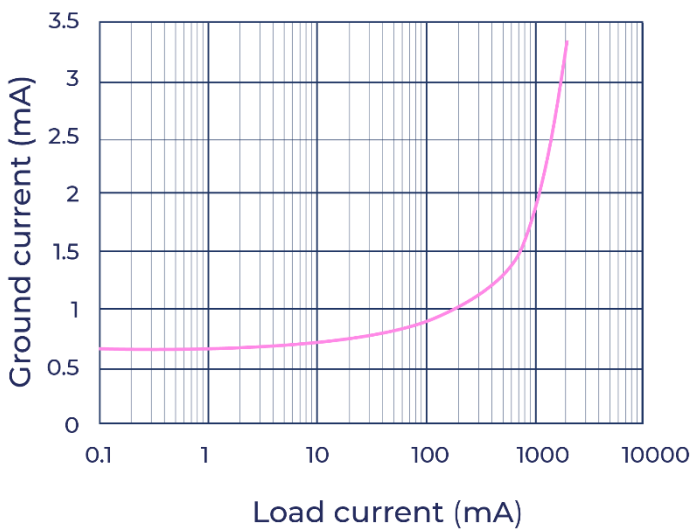

Figure 5. Ground current vs Load current

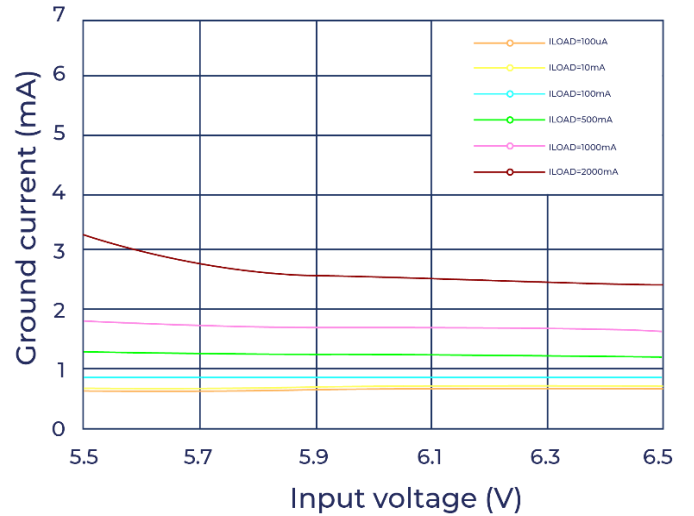

Figure 6. Ground current vs Input voltage

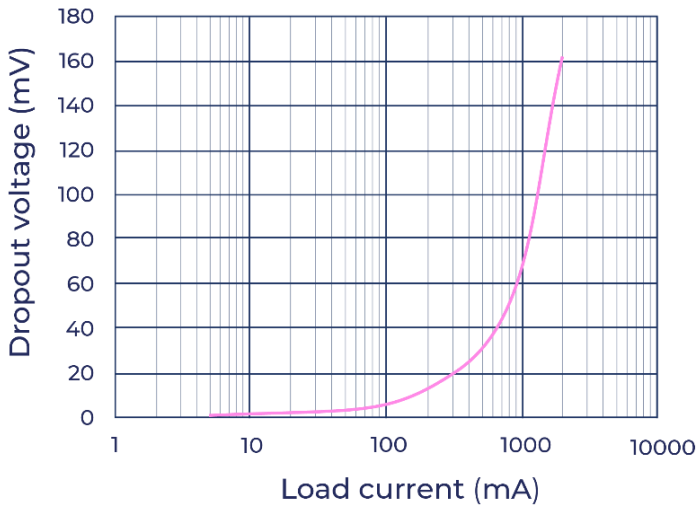

Figure 7. Dropout voltage vs Load current (1.2 V Adjustable version &  $V_{OUT} = 5\text{ V}$ )

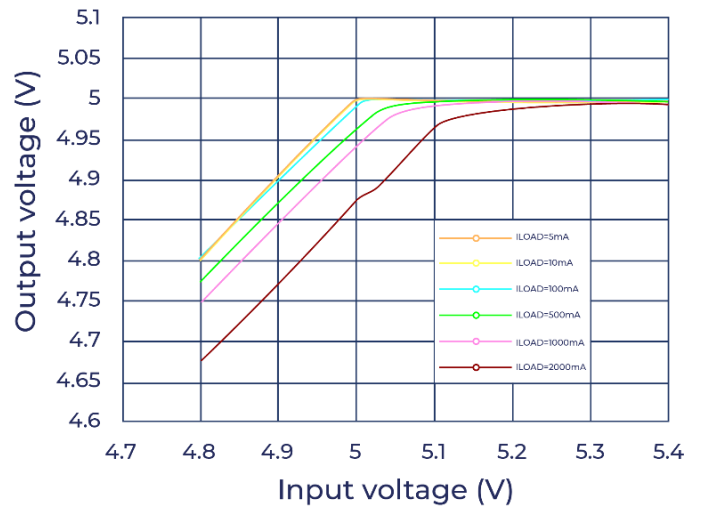

Figure 8. Output voltage vs Input voltage in dropout (1.2 V Adjustable version &  $V_{OUT} = 5\text{ V}$ )

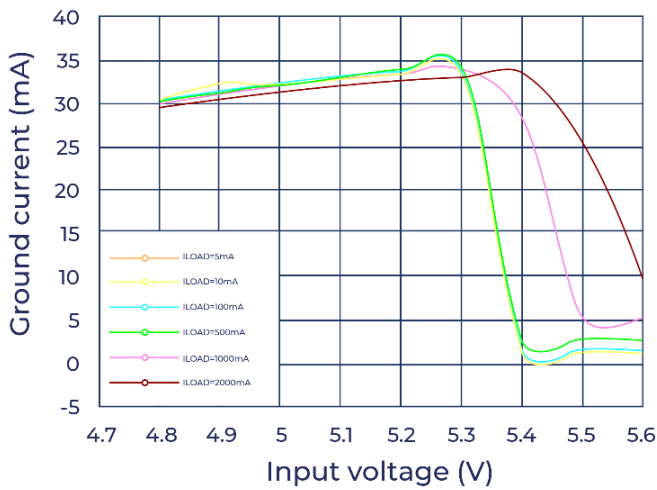

Figure 9. Ground current vs Input voltage in dropout (1.2 V Adjustable version &  $V_{OUT} = 5\text{ V}$ )

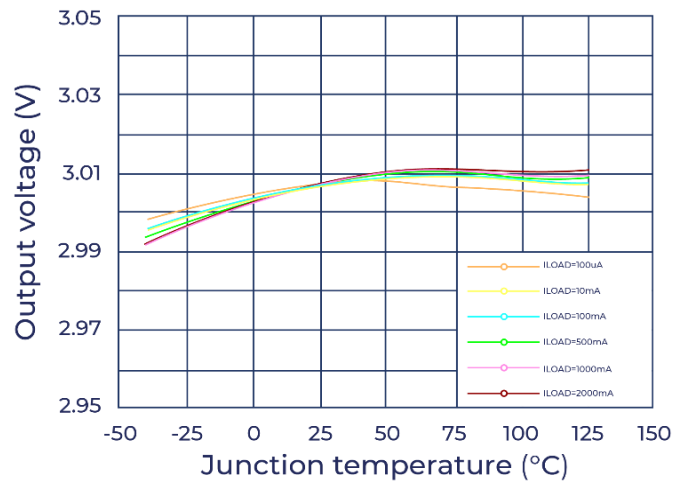

Figure 10. Output voltage vs Junction temperature ( $V_{OUT} = 3\text{ V}$ )

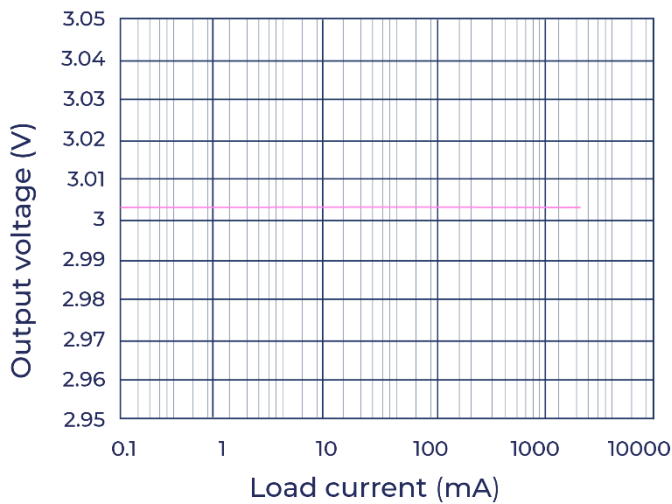

Figure 11. Output voltage vs Load current ( $V_{OUT} = 3\text{ V}$ )

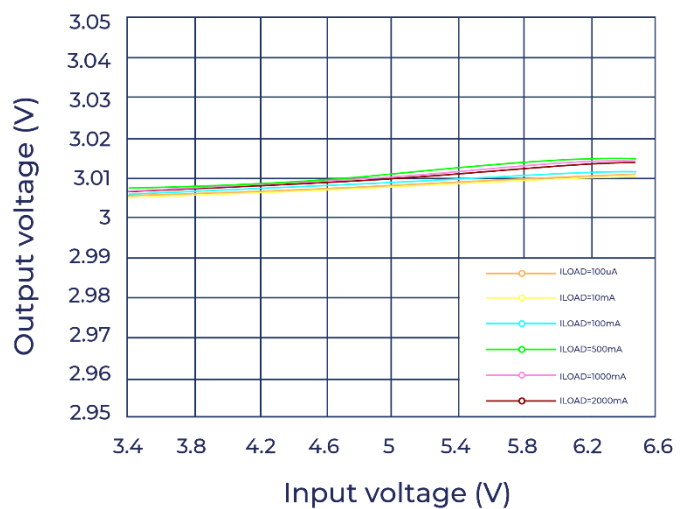

Figure 12. Output voltage vs Input voltage ( $V_{OUT} = 3\text{ V}$ )

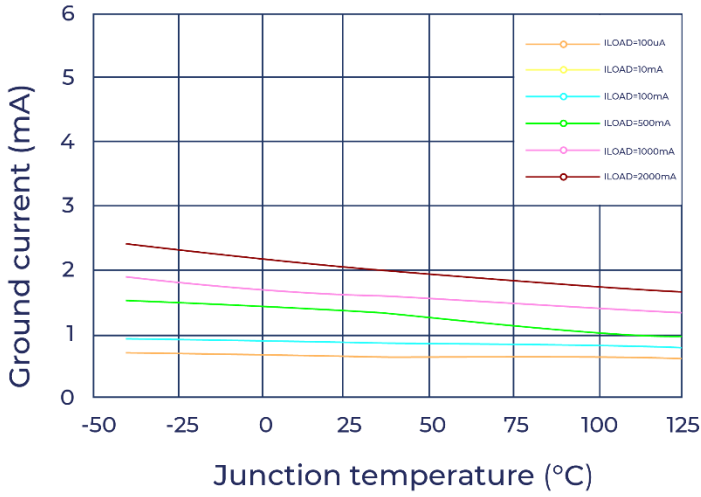

Figure 13. Ground current vs Junction temperature ( $V_{OUT} = 3\text{ V}$ )

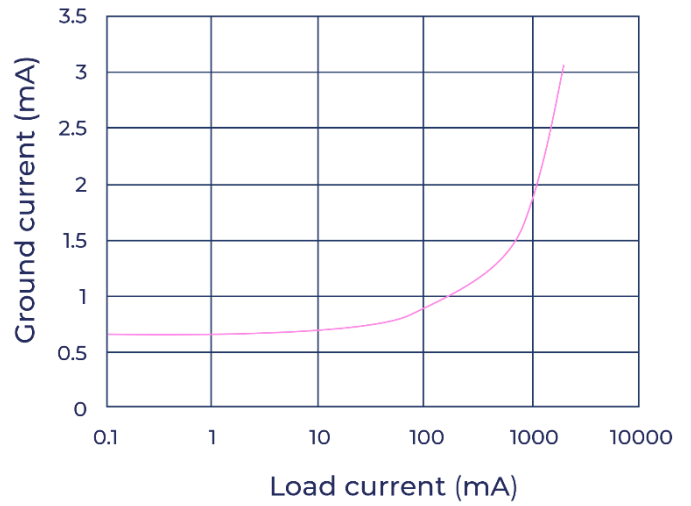

Figure 14. Ground current vs Load current ( $V_{OUT} = 3\text{ V}$ )

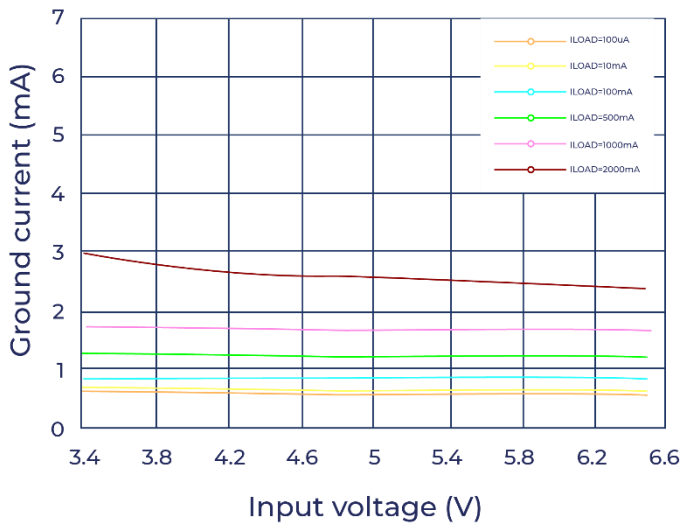

Figure 15. Ground current vs Input voltage ( $V_{OUT} = 3\text{ V}$ )

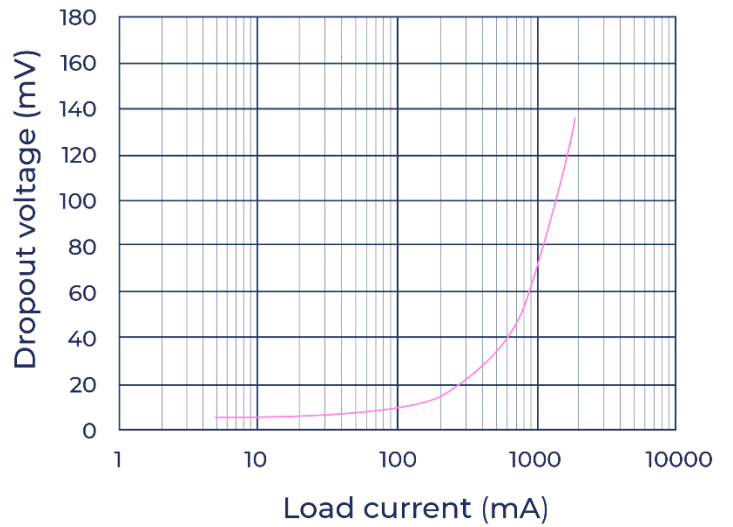

Figure 16. Dropout voltage vs Load current ( $V_{OUT} = 3\text{ V}$ )

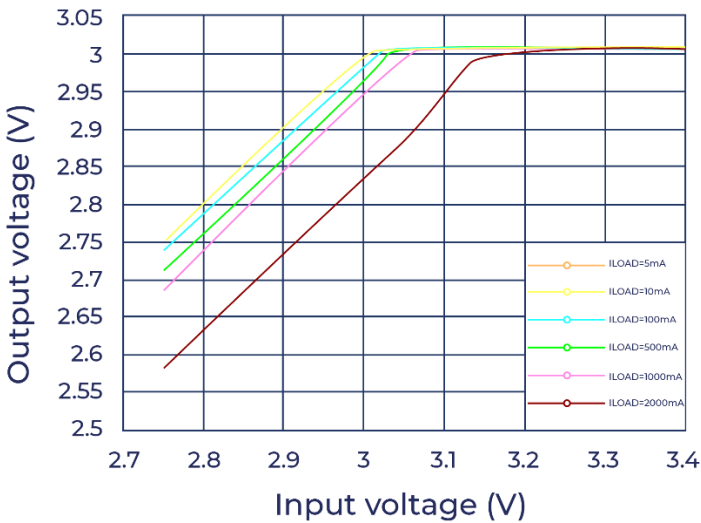

Figure 17. Output voltage vs Input voltage in dropout ( $V_{OUT} = 3\text{ V}$ )

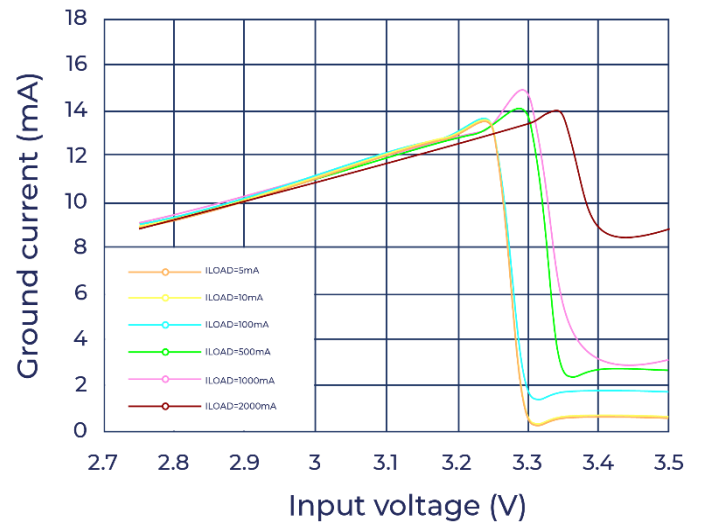

Figure 18. Ground current vs Input voltage in dropout ( $V_{OUT} = 3\text{ V}$ )

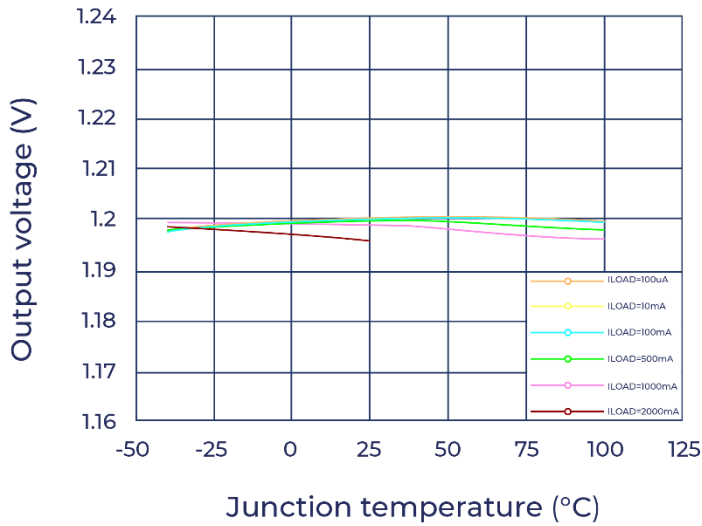

Figure 19. Output voltage vs Junction temperature Adjustable version ( $V_{OUT} = 1.2\text{ V}$ )

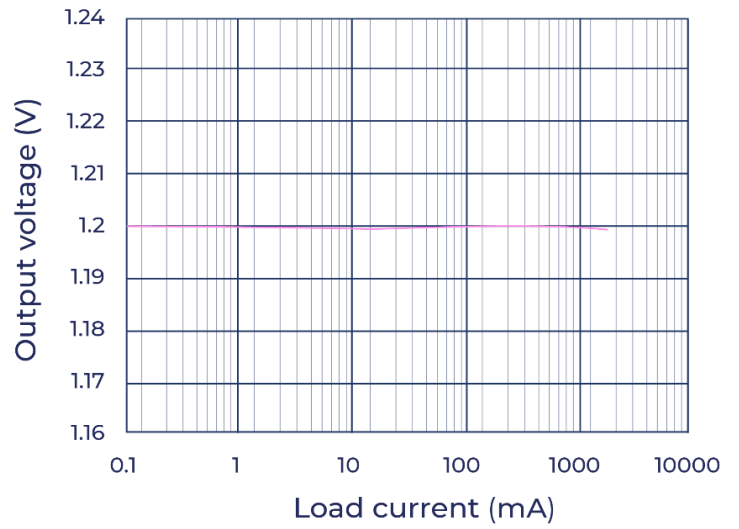

Figure 20. Output voltage vs Load current Adjustable version ( $V_{OUT} = 1.2\text{ V}$ )

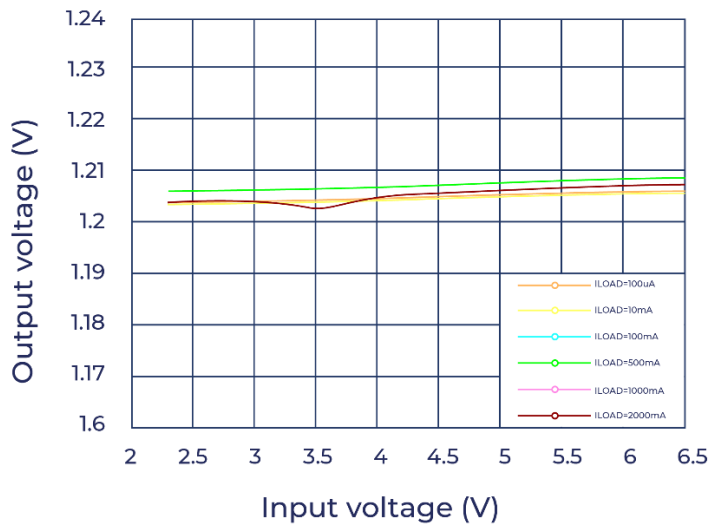

Figure 21. Output voltage vs Input voltage Adjustable version ( $V_{OUT} = 1.2\text{ V}$ )

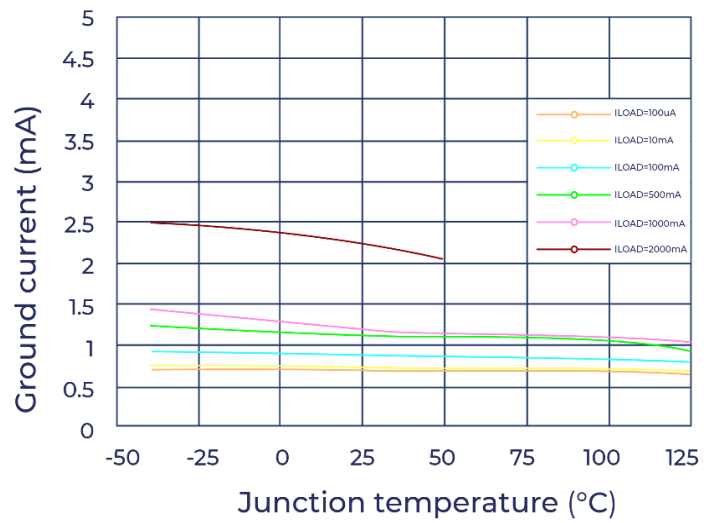

Figure 22. Ground current vs Junction temperature Adjustable version ( $V_{OUT} = 1.2\text{ V}$ )

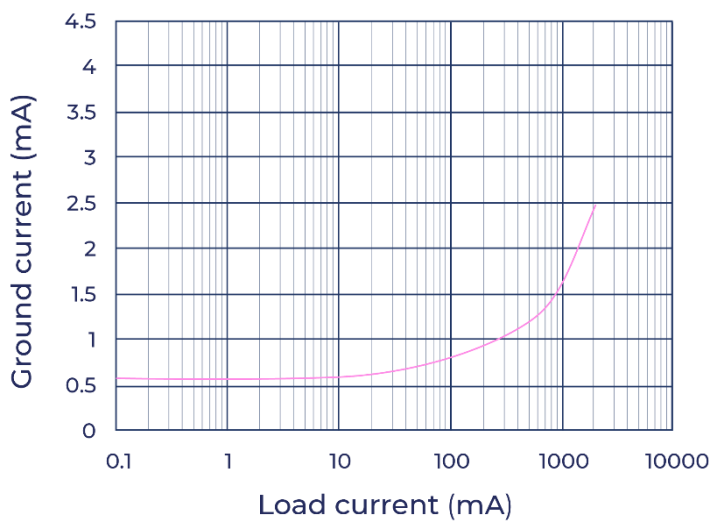

Figure 23. Ground current vs Load current Adjustable version ( $V_{OUT} = 1.2\text{ V}$ )

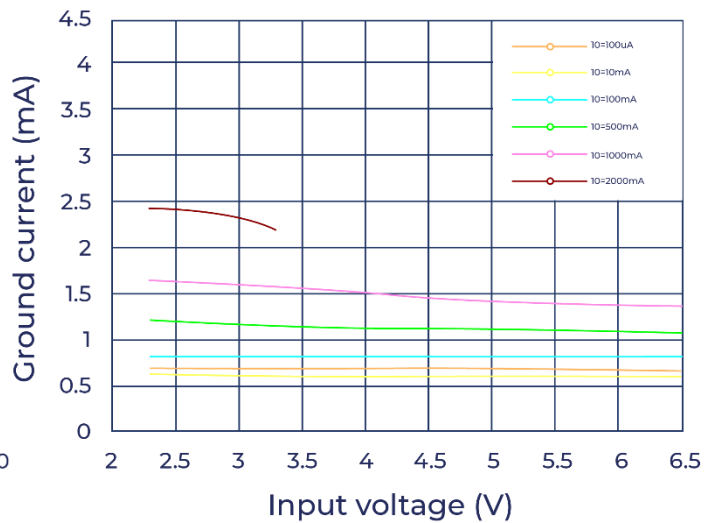

Figure 24. Ground current vs Input voltage Adjustable version ( $V_{OUT} = 1.2\text{ V}$ )

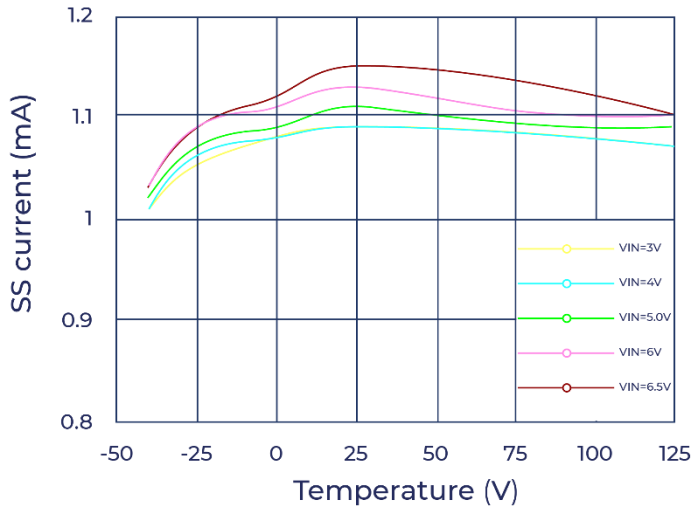

Figure 25. Soft start current vs Temperature, Input voltage (1.2 V Adjustable version &  $V_{OUT} = 5 V$ )

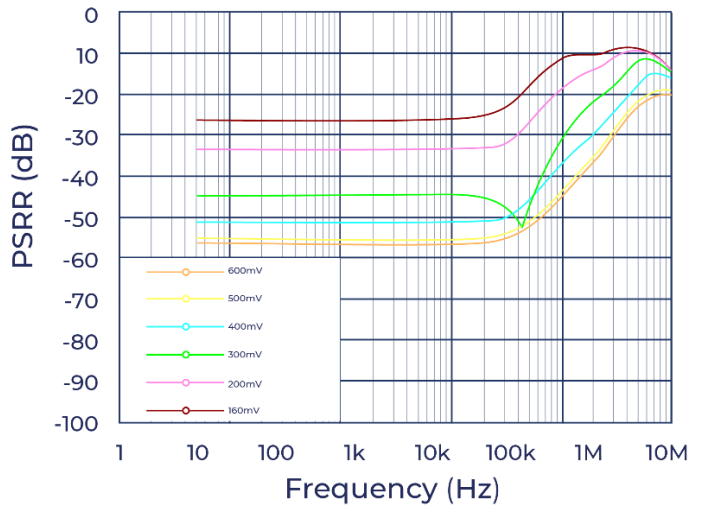

Figure 26. Power supply rejection ratio vs Frequency ( $V_{OUT} = 3 V$ , 2 A load current, Various headroom voltages)

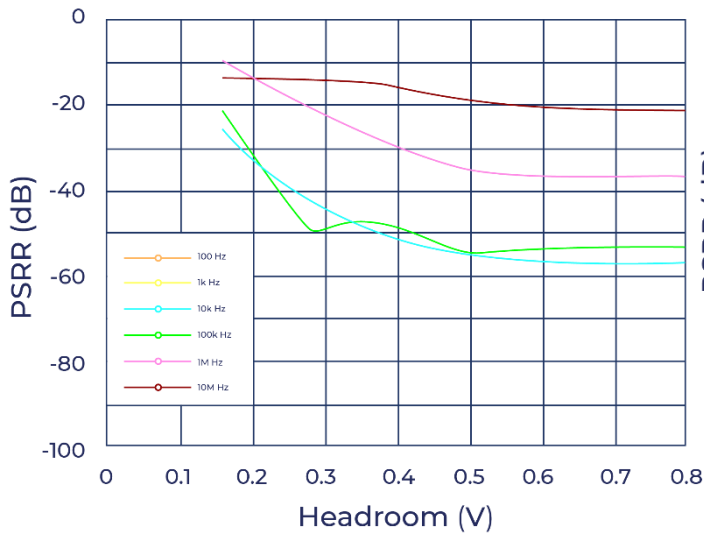

Figure 27. Power supply rejection ratio vs Headroom ( $V_{OUT} = 3 V$ , 2 A load current, Different Frequencies)

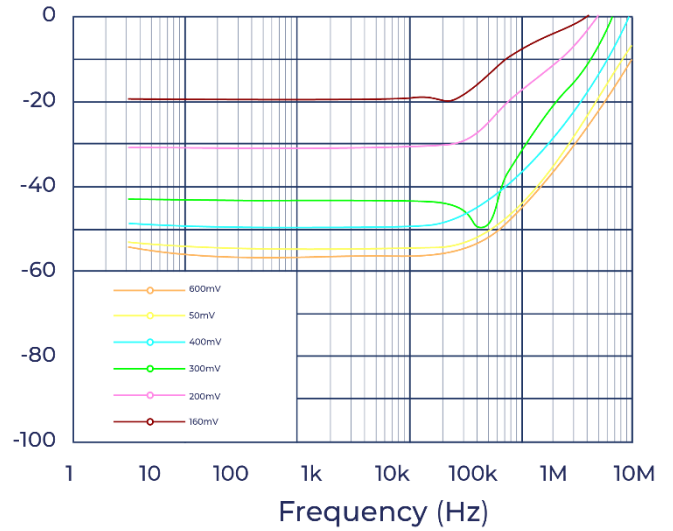

Figure 28. Power supply rejection ratio vs Frequency (1.2 V Adjustable version &  $V_{OUT} = 5 V$ , 2 A load current, Various headroom voltages)

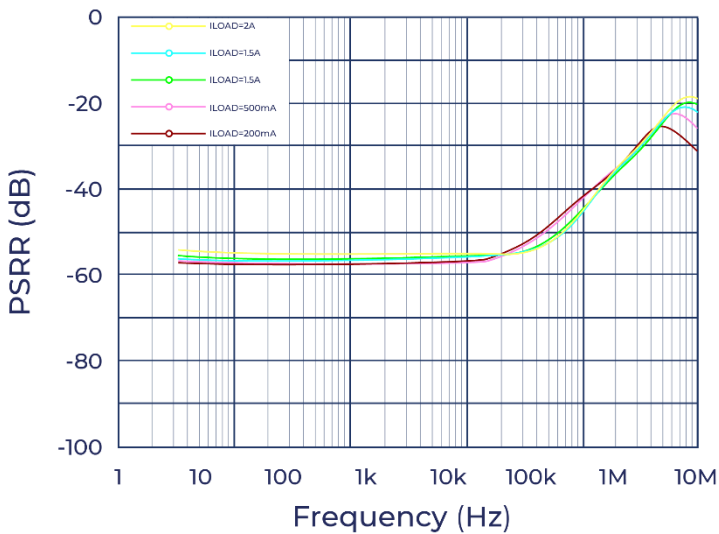

Figure 29. Power supply rejection ratio vs Frequency ( $V_{OUT} = 3 V$ , 500 mV headroom)

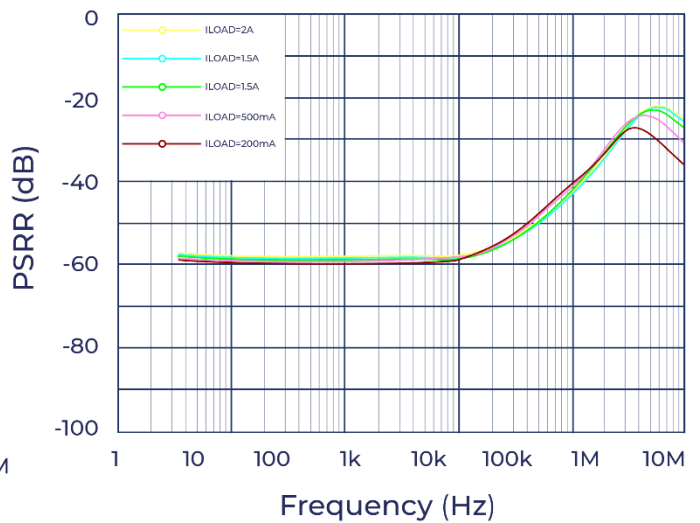

Figure 30. Power supply rejection ratio vs Frequency ( $V_{OUT} = 3 V$ , 800 mV headroom)

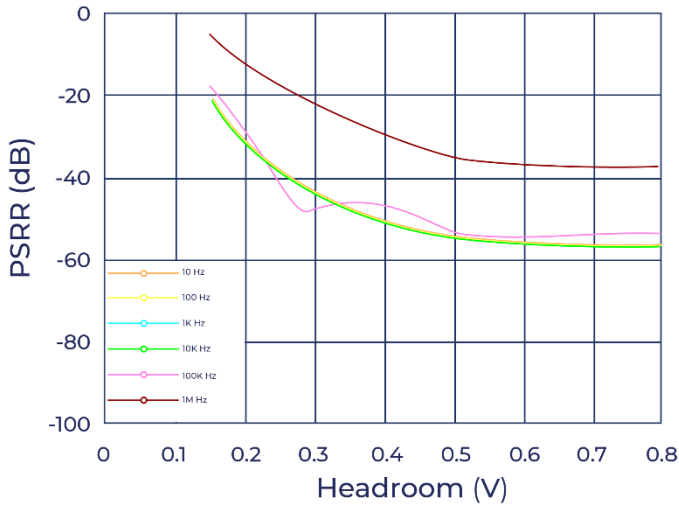

Figure 31. Power supply rejection ratio vs Headroom (1.2 V Adjustable version &  $V_{OUT} = 5$  V, 2 A load current, Different Frequencies)

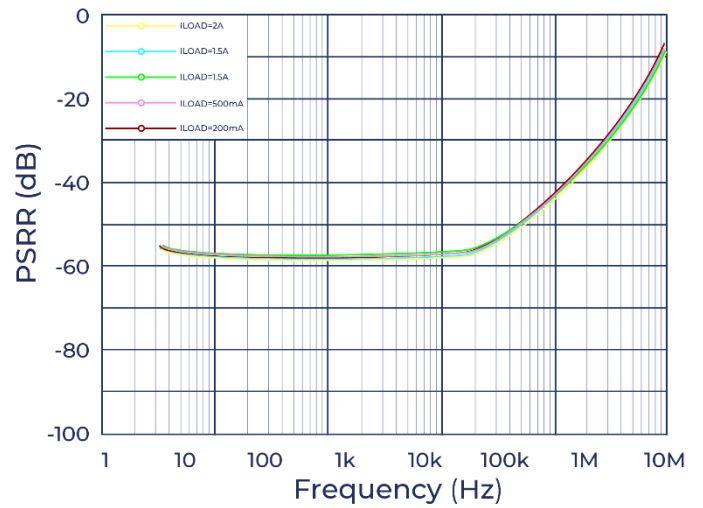

Figure 32. Power supply rejection ratio vs, Frequency (1.2 V Adjustable version &  $V_{OUT} = 5$  V, 800 mV headroom)

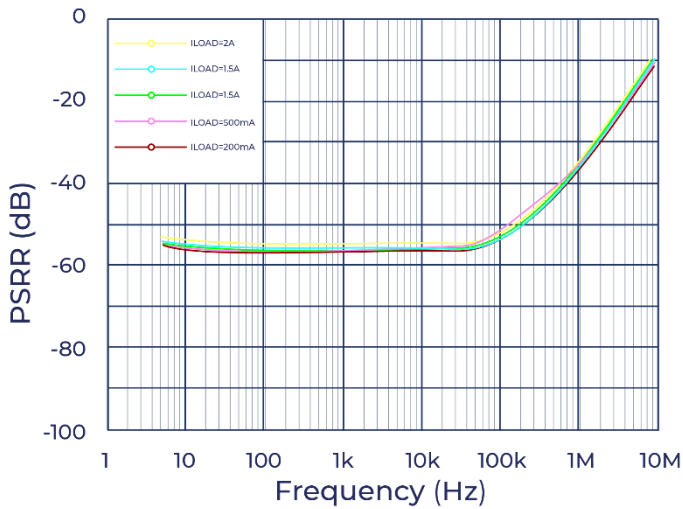

Figure 33. Power supply rejection ratio vs Frequency (1.2 V Adjustable version &  $V_{OUT} = 5$  V, 500mV headroom)

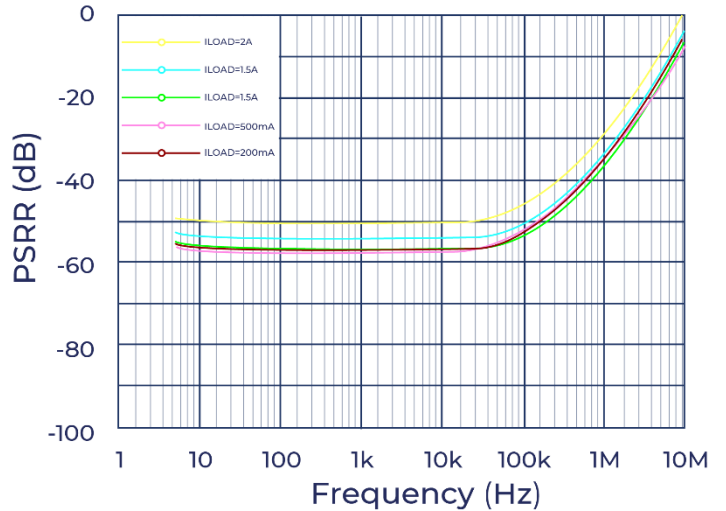

Figure 34. Power supply rejection ratio vs Frequency (1.2 V Adjustable version &  $V_{OUT} = 5$  V, 400 mV headroom)

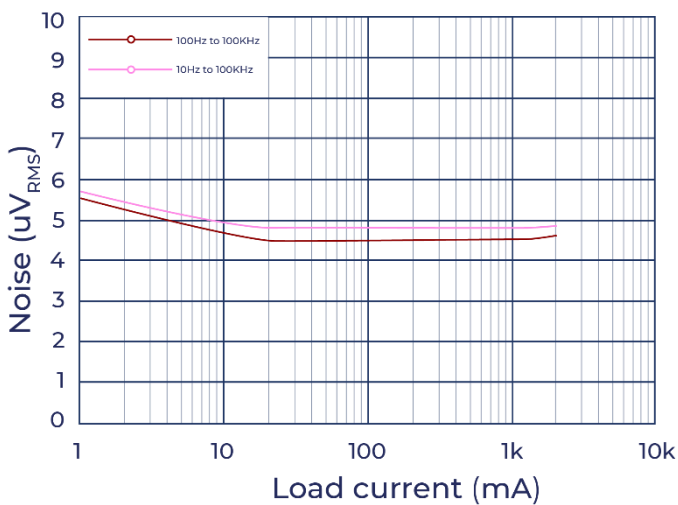

Figure 35. RMS Output Noise vs Load Current (Adjustable version  $V_{OUT} = 1.2$  V)

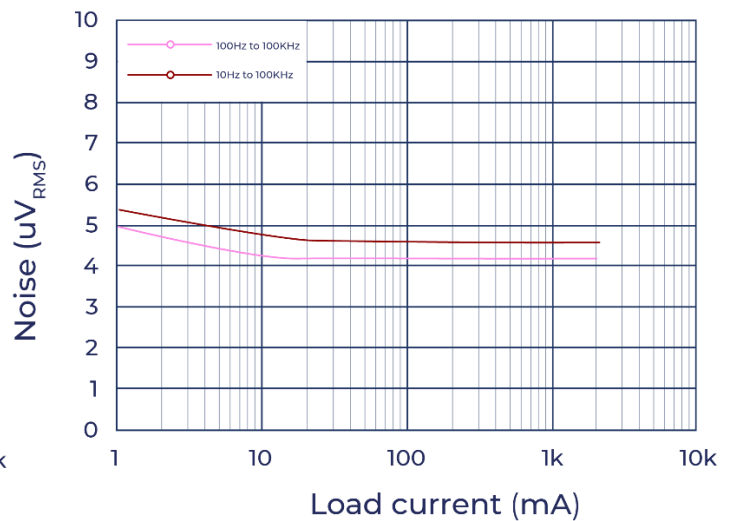

Figure 36. RMS Output Noise vs Load Current ( $V_{OUT} = 3$  V)

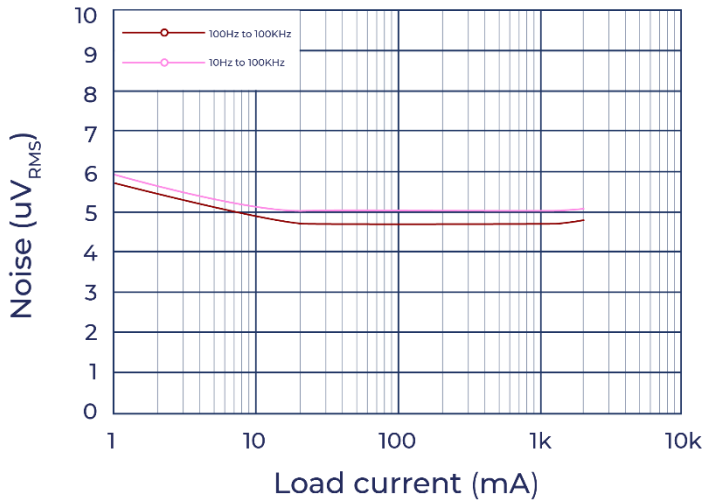

Figure 37. RMS Output Noise vs Load Current (1.2 V Adjustable version &  $V_{OUT} = 5\text{ V}$ )

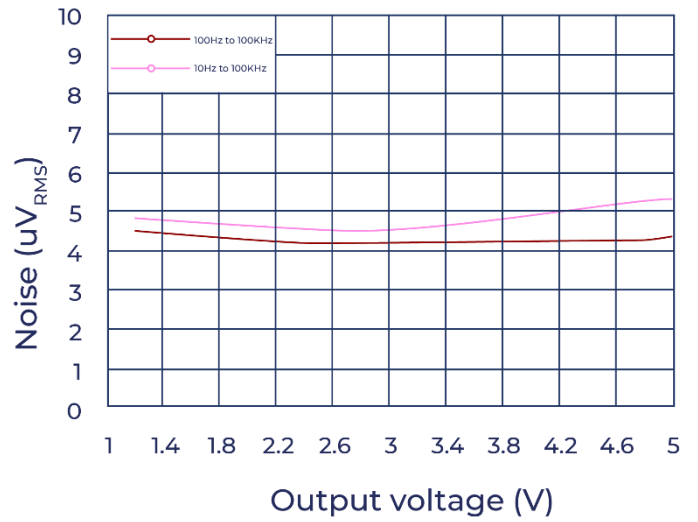

Figure 38. RMS Output Noise vs Output voltage (Load current = 100 mA)

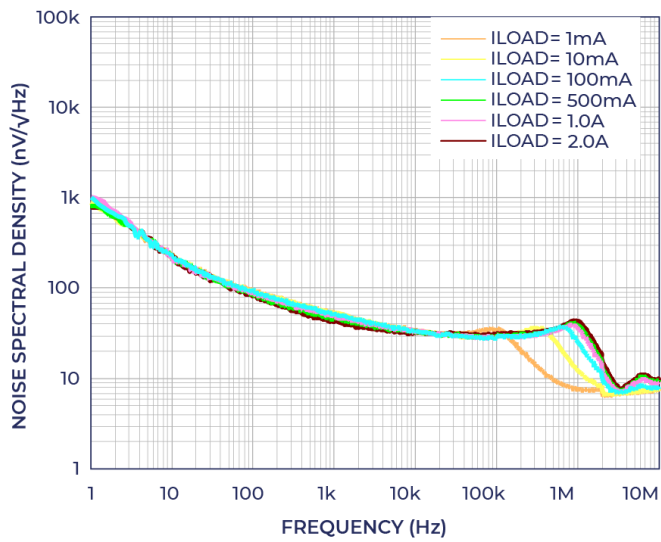

Figure 39. Output noise spectral density vs Frequency (Adjustable version  $V_{OUT} = 1.2\text{ V}$ )

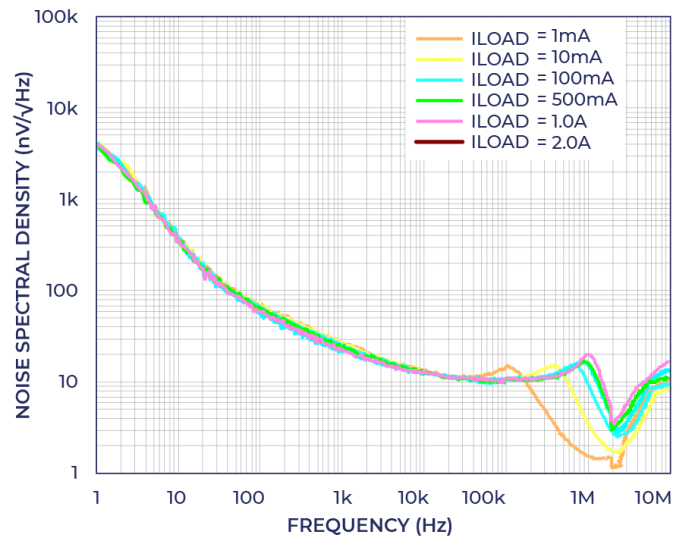

Figure 40. Output noise spectral density vs Frequency ( $V_{OUT} = 3\text{ V}$ )

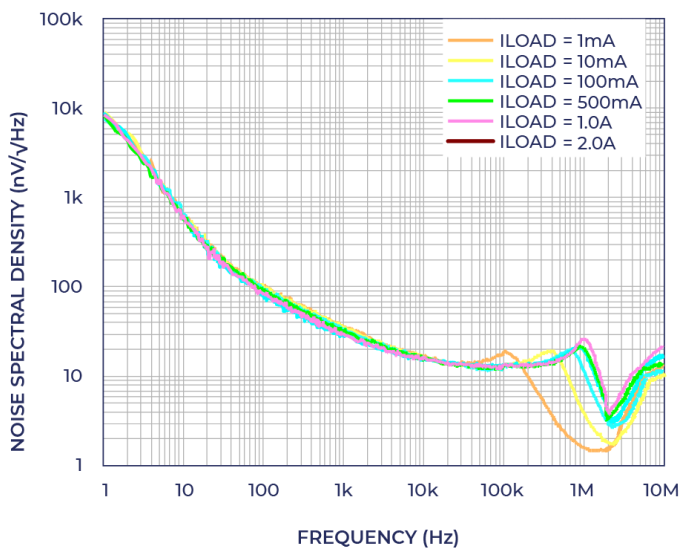

Figure 41. Output noise spectral density vs Frequency (1.2 V Adjustable version &  $V_{OUT} = 5\text{ V}$ )

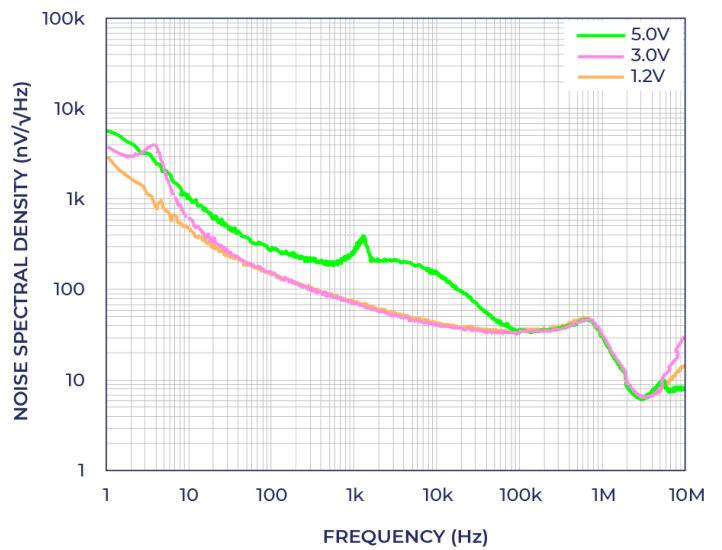
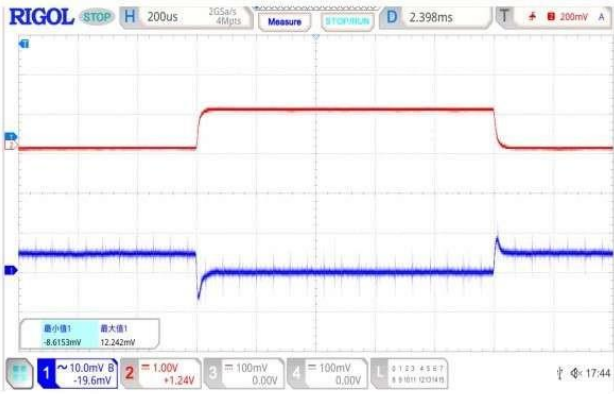
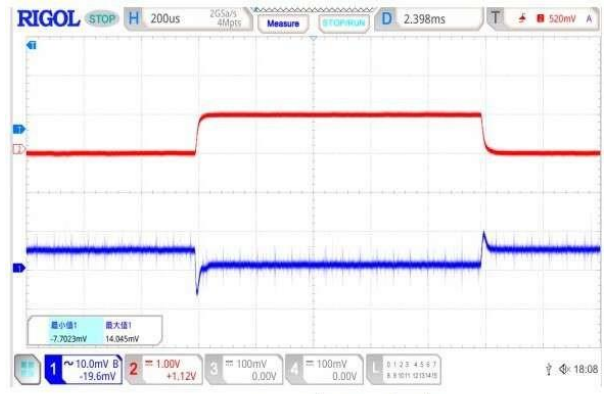

Figure 42. Output noise spectral density vs Frequency (Different output voltages,  $I_{LOAD} = 100\text{ mA}$ )



Time (200μs/div)

Figure 43. Load Transient Response,  $I_{LOAD} = 10$  mA to 1 A, 1.2 V Adjustable version &  $V_{OUT} = 5$  V,  $V_{IN} = 5.5$  V, CH1 =  $V_{OUT}$ , CH2 =  $I_{LOAD}$



Time (200μs/div)

Figure 44. Load Transient Response,  $I_{LOAD} = 100$  mA to 1.6 A, 1.2 V Adjustable version &  $V_{OUT} = 5$  V,  $V_{IN} = 5.5$  V, CH1 =  $V_{OUT}$ , CH2 =  $I_{LOAD}$

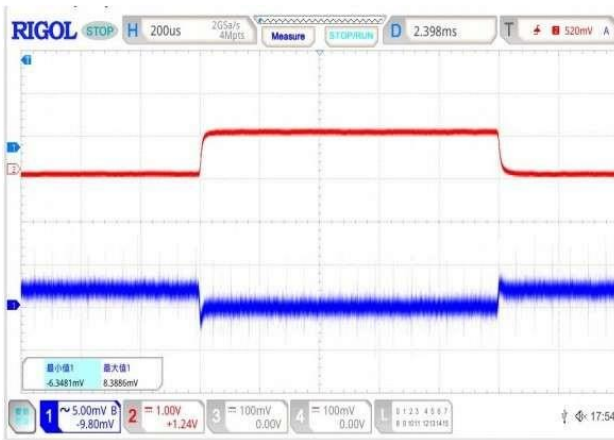

Time (200μs/div)

Figure 45. Load Transient Response,  $I_{LOAD} = 10$  mA to 1 A, Adjustable Version,  $V_{OUT} = 1.2$  V,  $V_{IN} = 2.5$  V, CH1 =  $V_{OUT}$ , CH2 =  $I_{LOAD}$

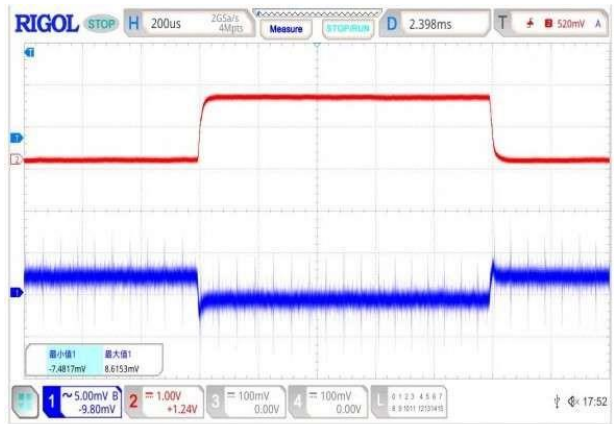

Time (200μs/div)

Figure 46. Load Transient Response,  $I_{LOAD} = 100$  mA to 1.6 A, Adjustable Version,  $V_{OUT} = 1.2$  V,  $V_{IN} = 2.5$  V, CH1 =  $V_{OUT}$ , CH2 =  $I_{LOAD}$



Time (20μs/div)

Figure 47. Line Transient Response, 6 V to 6.5 V,  $I_{LOAD} = 500$  mA, 1.2 V Adjustable version &  $V_{OUT} = 5$  V, CH1 =  $V_{IN}$ , CH2 =  $V_{OUT}$



Time (20μs/div)

Figure 48. Line Transient Response, 6 V to 6.5 V,  $I_{LOAD} = 2$  A, 1.2 V Adjustable version &  $V_{OUT} = 5$  V, CH1 =  $V_{IN}$ , CH2 =  $V_{OUT}$

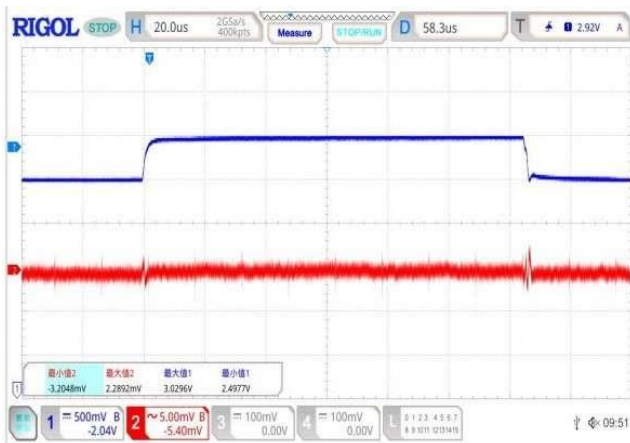

Time (20µs/div)

Figure 49. Line Transient Response, 2.5 V to 3 V,  $I_{LOAD} = 500$  mA, Adjustable Version,  $V_{OUT} = 1.2$  V, CH1 =  $V_{IN}$ , CH2 =  $V_{OUT}$



Time (20µs/div)

Figure 50. Line Transient Response, 2.5 V to 3V,  $I_{LOAD} = 2$  A, Adjustable Version,  $V_{OUT} = 1.2$  V, CH1 =  $V_{IN}$ , CH2 =  $V_{OUT}$

## Applications Information

TGS717X 6.5 V, 2 A, Ultralow Noise, High PSRR, CMOS LDO Regulators. The TGS717X is a low quiescent current, low dropout linear regulator that operates from 2.3 V to 6.5 V and provides up to 2 A of load current. Drawing a low 3.5 mA of quiescent current (typical) at full load makes the TGS717X ideal for portable equipment.

### Input Bypass Capacitor

Connecting a 4.7 µF capacitor from  $V_{IN}$  to GND reduces the circuit sensitivity to PCB layout, especially when long input traces or a high source impedance is encountered. If greater than 4.7 µF of output capacitance is required, increase the input capacitor to match it.

### Output Capacitor

The TGS717X is designed for operation with small, space-saving ceramic capacitors but functions with most commonly used capacitors as long as care is taken with regard to the ESR value. The ESR of the output capacitor affects the stability of the LDO control loop. A minimum of 4.7 µF capacitance with an ESR of 0.05 Ω or less is recommended to ensure the stability of the TGS717X. Transient response to changes in load current is also affected by output capacitance. Using a larger value of output capacitance improves the transient response of the TGS717X to large changes in load current.

### Programmable Precision Enable

The TGS717X has an EN pin to turn on or turn off the regulator, When the EN pin is in logic high, the regulator will be turned on. The shutdown current is almost 0.1 µA typical. The EN pin may be directly tied to  $V_{IN}$  to keep the part on. The Enable input is CMOS logic and cannot be left floating. The upper and lower thresholds are user programmable and can be set higher than the nominal 1.2 V threshold by using two resistors. The resistance values,  $R_{EN1}$  and  $R_{EN2}$ , can be determined from

$$R_{EN1} = R_{EN2} * (V_{IN} - 1.2 \text{ V}) / 1.2 \text{ V}$$

where:

$R_{EN2}$  is nominally 10 k $\Omega$  to 100 k $\Omega$ .  $V_{IN}$  is the desired turn-on voltage.

The hysteresis voltage increases by the factor  $(R_{EN1} + R_{EN2}) / R_{EN1}$

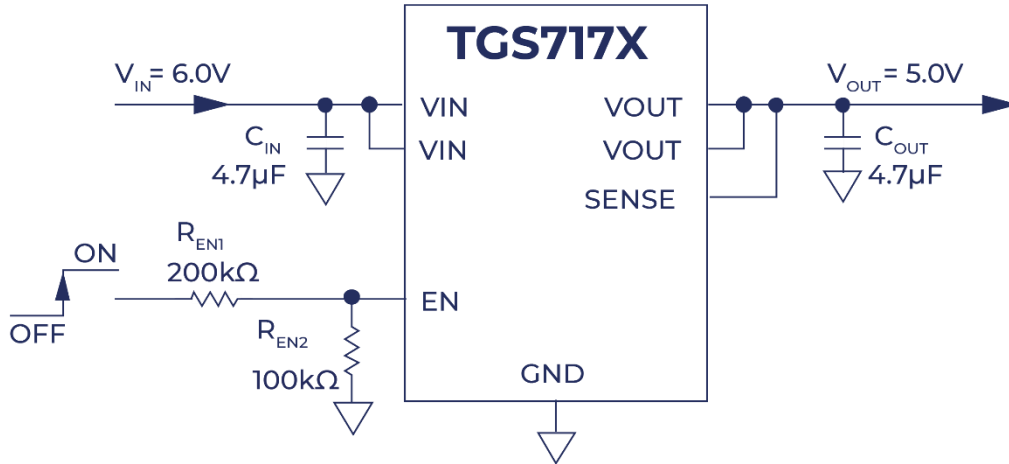

### Current Limit Protection

TGS717X 6.5 V, 2 A, Ultralow Noise, High PSRR, CMOS LDO Regulators When output current at the OUT pin is higher than current limit threshold, the current limit protection will be triggered and clamp the output current to approximately 3.3 A to prevent over-current and to protect the regulator from damage due to overheating.

### Soft Start

The TGS717X incorporates a Soft-Start function that reduces the start-up current surge into the output capacitor ( $C_{OUT}$ ) by allowing  $V_{OUT}$  to rise slowly to the final value.

### Thermal Shutdown

When the die temperature exceeds the Thermal Shutdown point ( $TSD = 150^{\circ}\text{C}$  typically) the device goes to disabled state and the output voltage is not delivered until the die temperature decreases to  $135^{\circ}\text{C}$ . The Thermal Shutdown feature provides a protection from a catastrophic device failure at accidental overheating. This protection is not intended to be used as a substitute for proper heat sinking. Power

### Dissipation and Heat sinking

The maximum power dissipation supported by the device is dependent upon board design and layout. Mounting pad configuration on the PCB, the board material and the ambient temperature affect the rate of junction temperature rise for the part. The maximum power dissipation the TGS717X device can handle is given by:

$$P_{D(MAX)} = (T_{J(MAX)} - T_A) / \theta_{JA}$$

where  $T_{J(MAX)}$  is the maximum junction temperature,  $T_A$  is the ambient temperature, and  $\theta_{JA}$  is the

junction to ambient thermal resistance. For recommended operating condition specifications the maximum junction temperature is  $150^{\circ}\text{C}$  and  $T_A$  is the ambient temperature. The junction to ambient thermal resistance,  $\theta_{JA}$ , is layout dependent. The maximum power dissipation depends on the operating ambient temperature for fixed  $T_{J(\text{MAX})}$  and thermal resistance,  $\theta_{JA}$

### Application Circuits

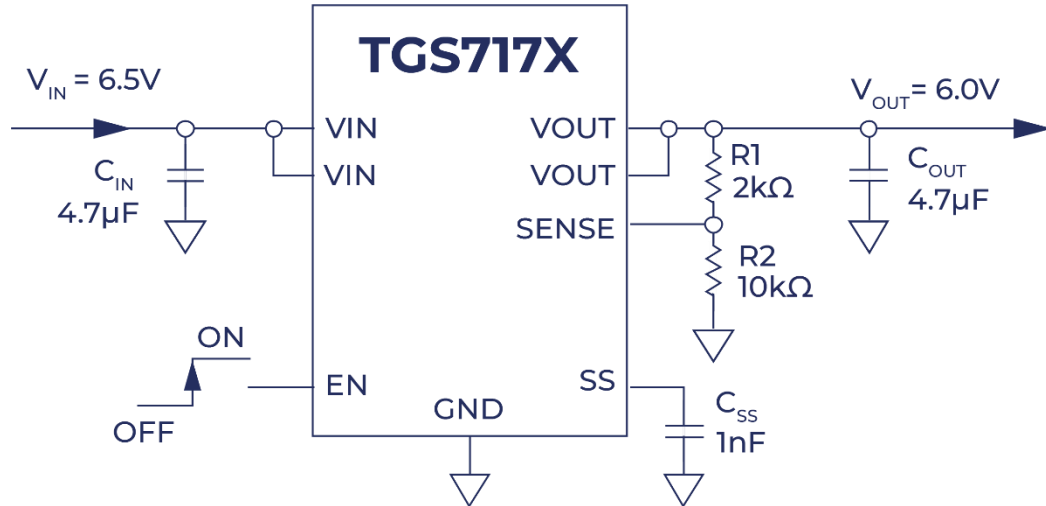

Typical Adjustable Output Voltage Application Schematic

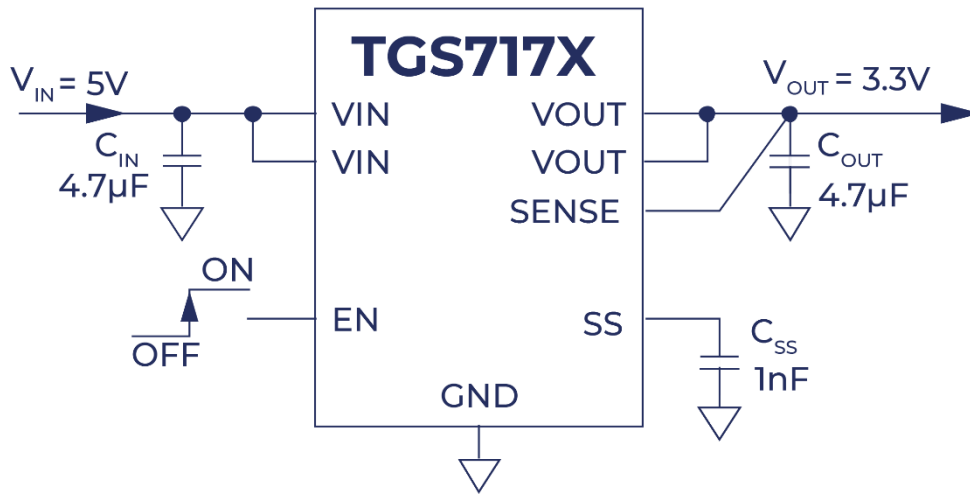

Fixed Output Voltage, 3.3 V

**Package Dimension (Unit: mm)**

