



TGS1573, TGS1574

1553B Monolithic Dual Transceiver

Data sheet

1. Description

The TGS1573 is low power CMOS dual transceivers designed to meet the requirements of the MIL-STD-1553 specification.

The transmitter section of each bus takes complementary CMOS / TTL Manchester II bi-phase data and converts it to differential voltages suitable for driving the bus isolation transformer. Separate transmitter inhibit control signal are provided for each transmitter.

The receiver section of each bus converts the 1553 bus bi-phase differential data to complementary CMOS / TTL data suitable for input to a Manchester decoder. Each receiver has a separate enable input, which forces the receiver outputs to logic "0" (TGS1573) or logic "1" (TGS1574).

TGS1573 can pin-to-pin replace HI-1573, TGS1574 can pin-to-pin replace HI-1574.

2. Features

- Compliant to MIL-STD-1553A and B, ARINC 708A
- Data rate up to 1 Mbps
- Power supply voltage range 3.3 V \pm 5%
- Operating Temperature range -55°C ~ +125°C

3. Technical Description

3.1 Pin configurations

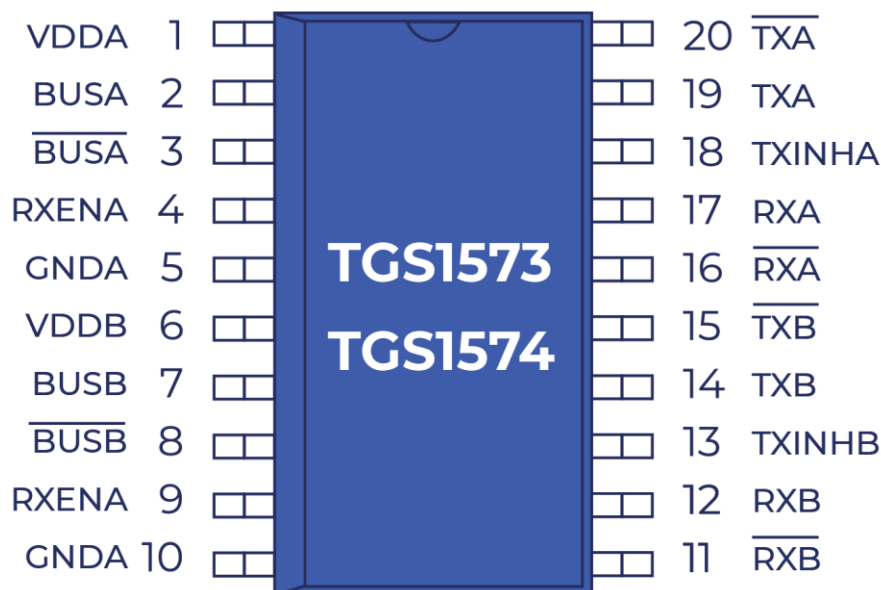

Fig.1 20-pin ESOP-20

3.2 Pin Description

Table 1. TGS1573 Pin Description

Pin	Symbol	Function	Description
1	VDDA	Power supply	+3.3-volt power for transceiver A
2	BUSA	Analog	MIL-STD-1533 bus driver A, positive signal
3	$\overline{\text{BUSA}}$	Analog	MIL-STD-1553 bus driver A, negative signal
4	RXENA	Digital input	Receiver A enable. If low, forces RXA and RXA low
5	GNDA	Power supply	Ground for transceiver A
6	VDDB	Power supply	+3.3-volt power for transceiver B
7	BUSB	Analog	MIL-STD-1533 bus driver B, positive signal
8	$\overline{\text{BUSB}}$	Analog	MIL-STD-1553 bus driver B, negative signal
9	RXENB	Digital input	Receiver B enable. If low, forces RXB and RXB low (TGS1573) or High (TGS1574)
10	GNDB	Power supply	Ground for transceiver B
11	$\overline{\text{RXB}}$	Digital output	Receiver B output, inverted
12	RXB	Digital output	Receiver B output, non-inverted
13	TXINHB	Digital input	Transmit inhibit, bus B. If high BUSB, BUSB disabled
14	TXB	Digital input	Transmitter B digital data input, non-inverted
15	$\overline{\text{TXB}}$	Digital input	Transmitter B digital data input, inverted
16	$\overline{\text{RXA}}$	Digital output	Receiver A output, inverted
17	RXA	Digital output	Receiver A output, non-inverted
18	TXINHA	Digital input	Transmit inhibit, bus A. If high BUSA, BUSA disabled
19	TXA	Digital input	Transmitter A digital data input, non-inverted
20	$\overline{\text{TXA}}$	Digital input	Transmitter A digital data input, inverted

3.3 Functional Description

The TGS1573 family of data bus transceivers contain differential voltage source drivers and differential receivers. They are intended for applications using a MIL-STD-1553 A/B data bus. The device produces a trapezoidal output waveform during transmission.

3.3.1 Transmitter

Data input to the device's transmitter section is from the complementary CMOS inputs TXA/B and $\overline{\text{TXA/B}}$. The transmitter accepts Manchester II bi-phase data and converts it to differential voltages on BUSA/B and $\overline{\text{BUSA/B}}$. The transceiver outputs are either director transformer-coupled to the MIL-STD-1553 data bus. Both coupling methods produce a nominal voltage on the bus of 7.5 volts peak to peak.

The transmitter is automatically inhibited and placed in the high impedance state when both TXA/B and $\overline{\text{TXA/B}}$ are driven with the same logic state. A logic "1" applied to the TXINHA/B input will force the transmitter to the high impedance state, regardless of the state of TXA/B and $\overline{\text{TXA/B}}$.

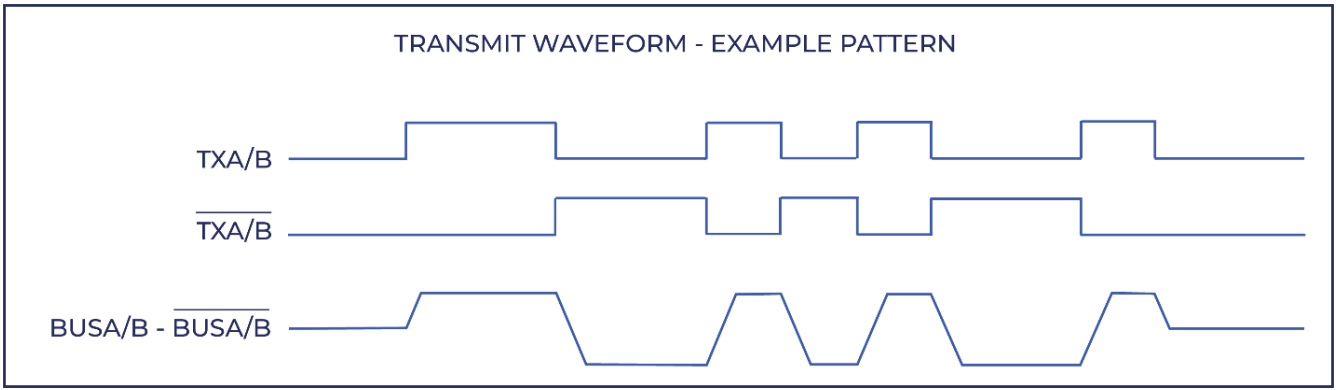

Fig. 2 Transmit Wave

3.3.2 Receiver

The receiver accepts bi-phase differential data from the MIL- STD-1553 bus through the same director transformer- coupled interface as the transmitter.

The receiver’s differential input stage drives a filter and threshold comparator that produces CMOS data at the RXA/B and RXA/B output pins. When the MIL-STD-1553 bus is idle and RXENA or RXENB are high, RXA/B will be logic “0” on TGS1573 and logic “1” on TGS1574. The receiver outputs are forced to the bus idle state (logic “0” on TGS1573 or logic “1” on TGS1574) when RXENA or RXENB is low.

3.3.3 MIL-STD-1553 Bus Interface

A direct-coupled interface (see Figure 5) uses a 1:2.5 ratio isolation transformer and two 55-ohm isolation resistors between the transformer and the bus.

In a transformer-coupled interface (see Figure 6), the transceiver is connected to a 1:1.79 isolation transformer which in turn is connected to a 1:1.4 coupling transformer. The transformer- coupled method also requires two coupling resistors equal to 75% of the bus characteristic impedance (Z_0) between the coupling transformer and the bus.

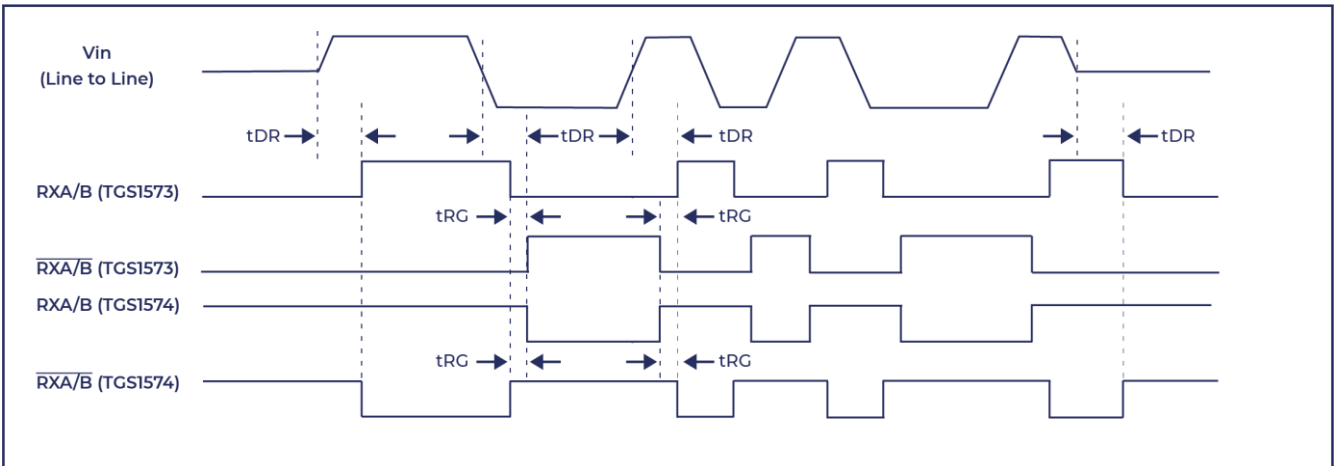

Fig. 3 Receive Waveform

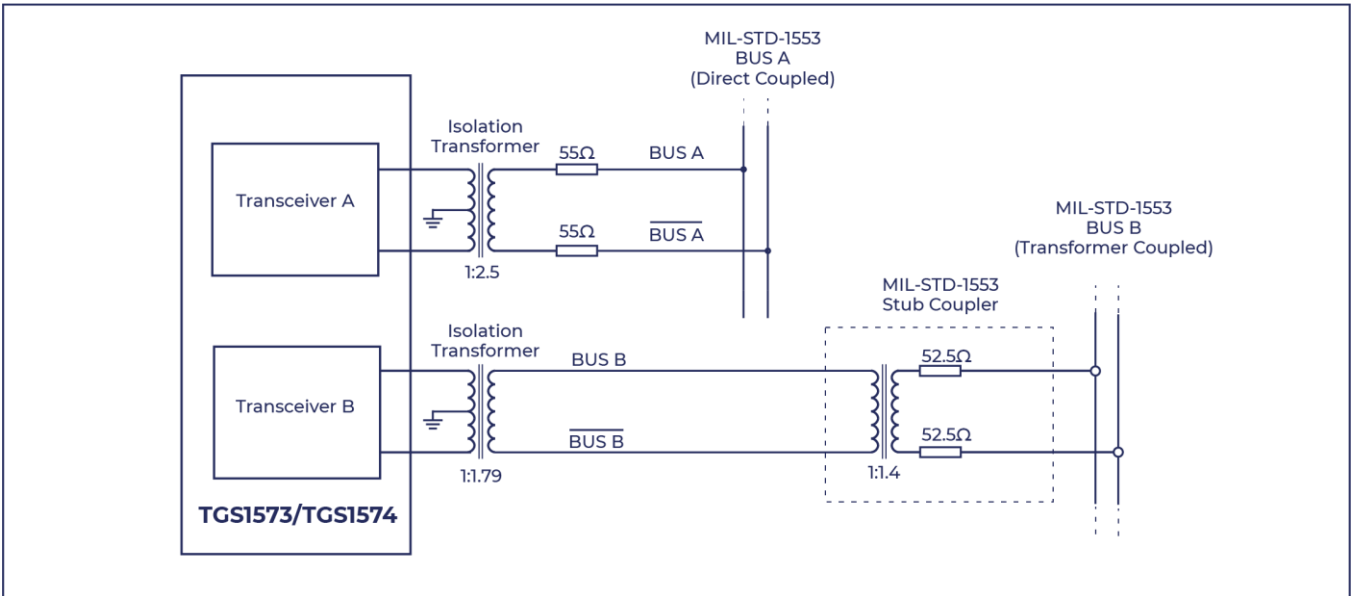

Fig. 4 Bus Connection Example using TGS1573 or TGS1574

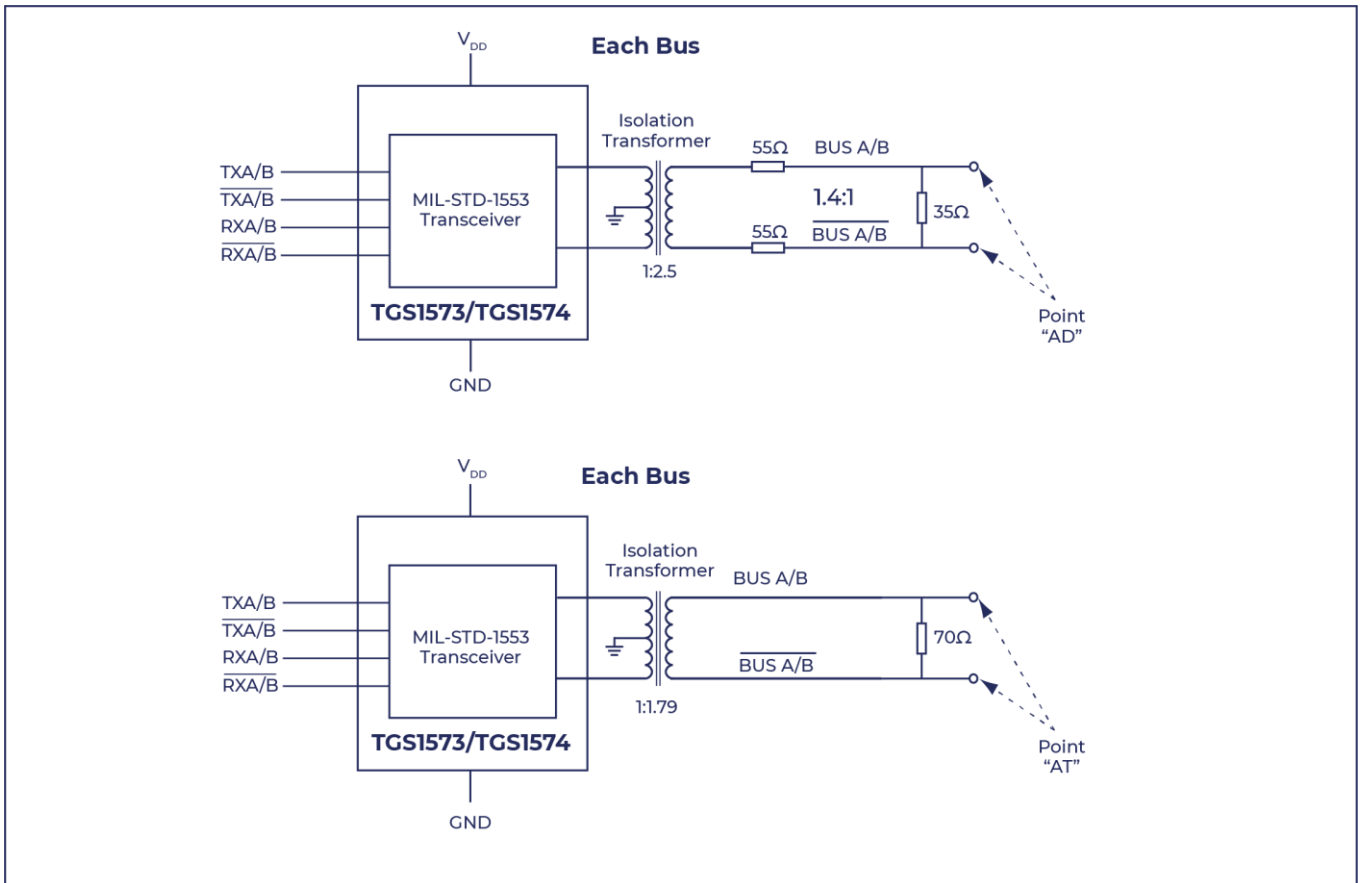

Fig. 5 Transformer Coupled Test Circuit

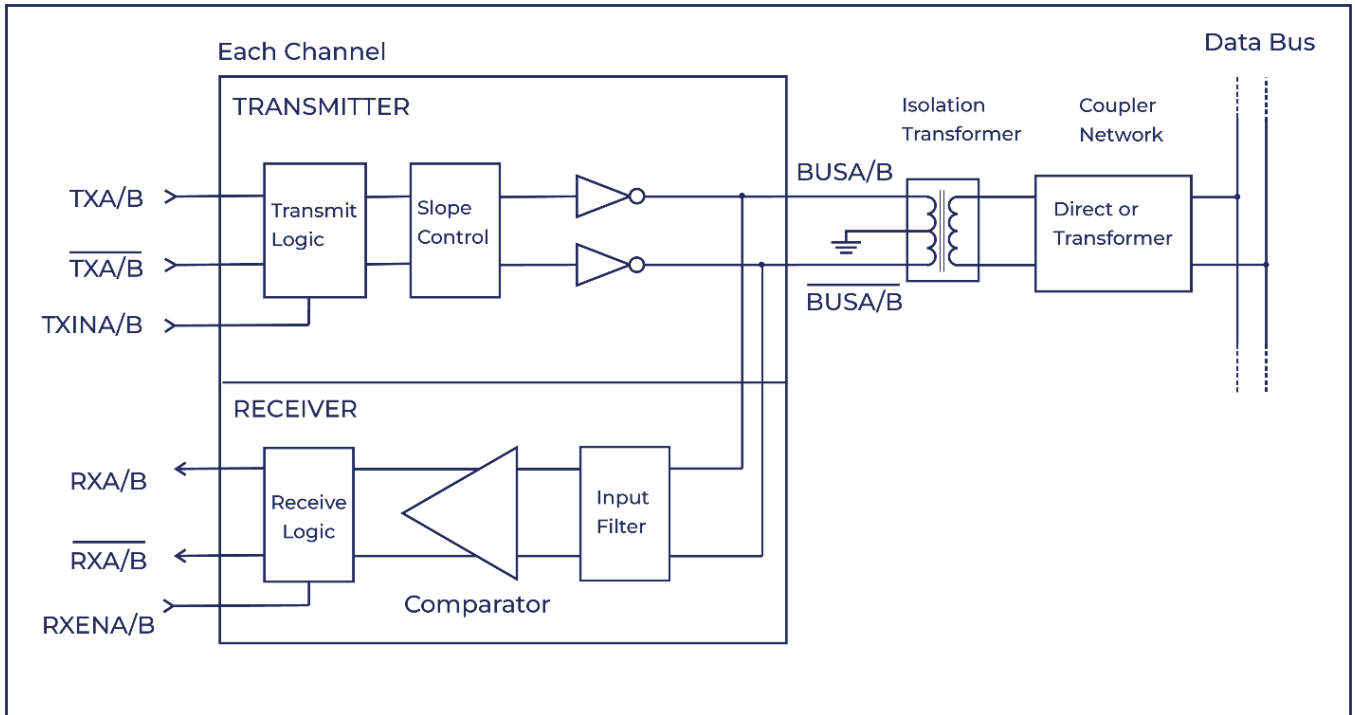

Fig. 6 TGS1573/ TGS1574 Block diagram

3.5 Absolute maximum ratings

- Supply voltage: V_D (-0.3 V to +5 V)
- Logic input voltage range: V_{IN} (-0.3 V to +3.6 V)
- Receiver differential voltage: 50 V_{P-P}
- Driver peak output current: 1.0 A
- Storage Temperature: -65°C to +150°C
- Solder Reflow Temperature: 260°C
- Operating Temperature: -40°C to +125°C

3.6 Parameters

3.6.1 DC Electrical characteristics

$V_{DD} = 3.3$ V, $T_A =$ Operating Temperature Range (unless otherwise specified), GND = 0 V

Parameters	Symbol	Condition	Min.	Typ.	Max.	Units
Operating Voltage	V_{DD}		3.15	3.30	3.45	V
Total Supply Current	I_{CC1}	Not Transmitting		10	17	mA
	I_{CC2}	Transmit one bus @ 50% duty cycle		210	225	mA
	I_{CC3}	Transmit one bus @ 100 % duty cycle		420	450	mA

Parameters	Symbol	Condition	Min.	Typ.	Max.	Units	
Power Dissipation	P _{D1}	Not Transmitting	-	0.033	0.060	W	
	P _{D2}	Transmit one bus @ 100 % duty cycle		0.475	0.550	W	
Min. Input Voltage (HI)	V _{IH}	Digital inputs	70%	-	-	V _{DD}	
Max. Input Voltage (LO)	V _{IL}	Digital inputs	-	-	30%	V _{DD}	
Min. Input Current (HI)	I _{IH}	Digital inputs	-	-	20	μA	
Max. Input Current (LO)	I _{IL}	Digital inputs	-20	-	-	μA	
Min. Output Voltage (HI)	V _{OH}	I _{OUT} = -1.0 mA, Digital inputs	90%	-	-	V _{DD}	
Max. Output Voltage (LO)	V _{OL}	I _{OUT} = -1.0 mA, Digital inputs	-	-	10%	V _{DD}	
RECEIVER (Measured at Point «AD» in Figure 5 unless otherwise specified)							
Input resistance	R _{IN}	Differential (at chip pins)	20	-	-	KΩ	
Input resistance	C _{IN}	Differential	-	-	5	pF	
Common mode rejection ratio	CMRR		40	-	-	dB	
Input Level	V _{IN}	Differential	-	-	9	V _{p-p}	
Input common mode voltage	V _{ICM}		-10	-	10	V-pk	
Threshold Voltage - Direct-coupled	Detect	V _{THD}	1 MHz Sine Wave Measured at Point «AD» in Figure 5	1.15	-	-	V _{p-p}
	No Detect	V _{THND}	No pulse at RXA/B, $\overline{RXA/B}$	-	-	0.28	V _{p-p}
Threshold Voltage - Transformer-coupled	Detect	V _{THD}	1 MHz Sine Wave Measured at Point «AD» in Figure 5	0.86	-	-	V _{p-p}
	No Detect	V _{THND}	No pulse at RXA/B, $\overline{RXA/B}$	-	-	0.20	V _{p-p}
TRANSMITTER (Measured at Point «AD» in Figure 5 unless otherwise specified)							
Output Voltage	Direct coupled	V _{OUT}	35Ω load	6.0	-	9.0	V _{p-p}
	Transformer coupled	V _{OUT}	70Ω load	18.0	-	27.0	V _{p-p}
Output Noise		V _{ON}	Differential, inhibited	-	-	10.0	mV _{p-p}
Output Dynamic Offset Voltage	Direct coupled	V _{DYN}	35Ω load	-90	-	90	mV
	Transformer coupled	V _{DYN}	70Ω load	-250	-	250	mV
Output resistance		R _{OUT}	Differential, not transmitting	10	-	-	KΩ
Output Capacitance		C _{OUT}	1MHz sine wave	-	-	15	pF

3.6.2 AC Electrical characteristics

$V_{DD} = 3.3\text{ V}$, $T_A = \text{Operating Temperature Range (unless otherwise specified)}$, $GND = 0\text{ V}$

Parameters	Symbol	Condition	Min.	Typ.	Max.	Units
RECEIVER (Measured at Point «AT» in Figure 5)						
Receiver Delay	t_{DR}	From input zero crossing to $\overline{RXA/B}$ or $\overline{RXA/B}$	-	-	500 ^[3]	ns
Receiver gap time	t_{RG}	Spacing between $\overline{RXA/B}$ and $\overline{RXA/B}$ pulses	60 ^[1]	-	430 ^[2]	ns
Receiver Enable Delay	t_{REN}	From $\overline{RXENA/B}$ rising or falling edge to $\overline{RXA/B}$ or $\overline{RXA/B}$	-	-	40	ns
TRANSMITTER (Measured at Point «AD» in Figure 5)						
Driver Delay	t_{DT}	$\overline{TXA/B}$, $\overline{TXA/B}$ to $\overline{BUSA/B}$, $\overline{BUSA/B}$	-	-	150	ns
Rise time	t_r	35 Ω load	100	-	300	ns
Fall Time	t_f	35 Ω load	100	-	300	ns
Inhibit Delay	t_{DI-H}	Inhibited output	-	-	100	ns
	t_{DI-L}	Active output	-	-	150	ns

[1]: Measured using a 1MHz sinusoid, 20 V peak to peak, line to line at point «AT» (Guaranteed but not tested).

[2]: Measured using a 1 MHz sinusoid, 860 mV peak to peak, line to line at point «AT» (100% tested).

[3]: Measured using a 1 MHz sinusoid, 860 mV peak to peak, line to line at point «AT». Measured from input zero crossing point.

4. Ordering information

Part Number	Operating Temperature	Package
TGS1573ESN1	-40°C to +125°C	ESOP-20
TGS1574ESN1	-40°C to +125°C	ESOP-20

5. Outlines

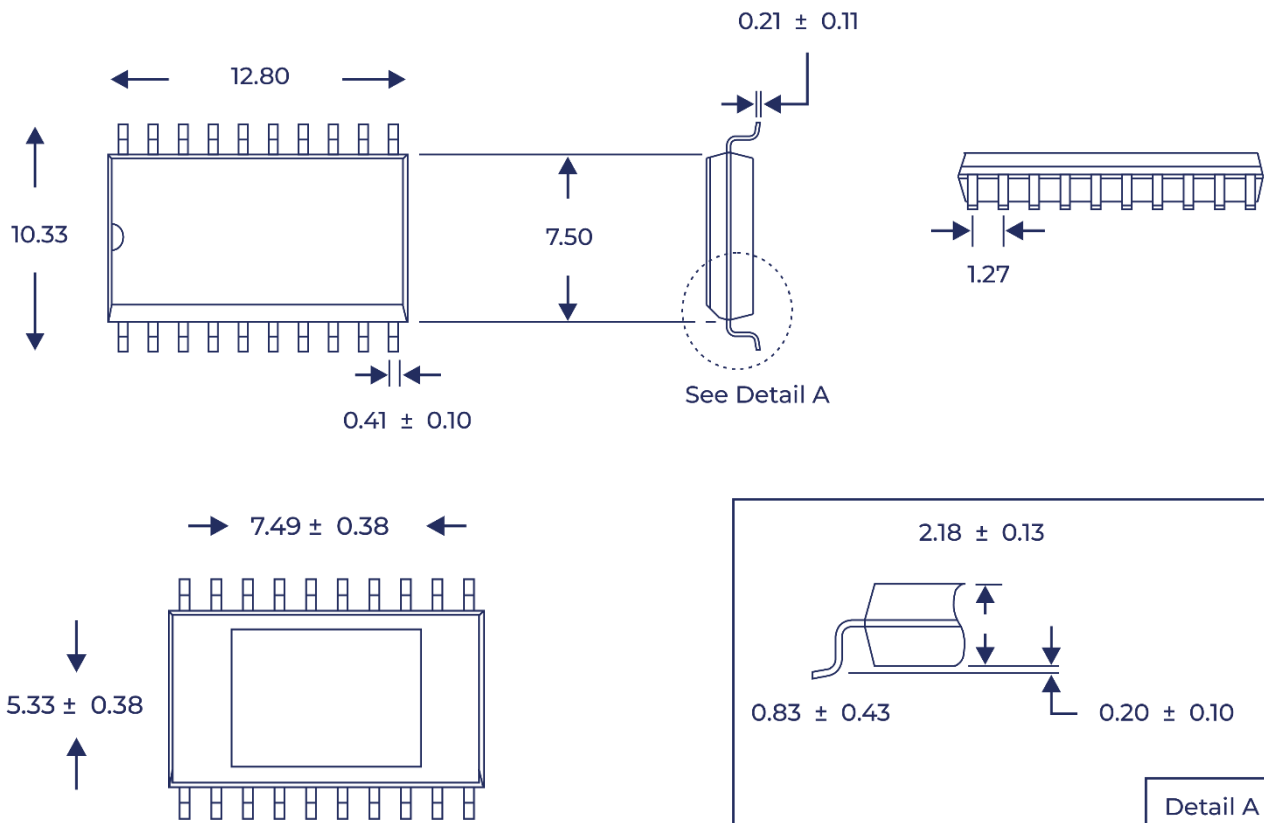

Product marking



First line: Part number model

Second line: Manufacturer date code*

Note*

YY - last two digits of the calendar year

WW - last two digits being the week of the year